

GREENZONE®
T E R M I T E S Y S T E M

INSTALLATION MANUAL

VERSION 7.2 – JANUARY 2026

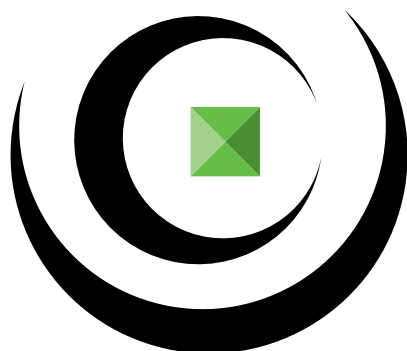

GREENZONE®
TERMITE & INSECT MANAGEMENT SYSTEMS

DISCLAIMER

This installation manual is subject to regular updates and changes. Accordingly, to ensure you are working with the most recent version of this manual – please go to www.greenzonebarrier.com to download the latest version of this manual. Or, contact Green Zone Pty Ltd directly.

Contact Details for Green Zone Pty Ltd.

Address: 25, 479 Warrigal Road, Moorabbin Victoria, Australia 3189
Postal: GPO Box 3196, Moorabbin East Victoria, Australia 3189
Telephone: +61 (0)3 9555 7876
Email: info@greenzonebarrier.com
Website: www.greenzonebarrier.com

Document Version: V 7.2 – January 2026
Copyright © 2026 Green Zone Pty Ltd.
GREENZONE® is a registered Trade Mark



TABLE OF CONTENTS

1.	INTRODUCTION	6
1.1	GREENZONE® TERMITE AND INSECT MANAGEMENT PRODUCTS	7
1.2	APPLICATIONS	11
1.3	GREENZONE® FEATURES & BENEFITS	13
1.4	GENERAL APPLICATIONS	13
1.5	INTELLECTUAL PROPERTY	13
2	TOOLS, PPE, SAFETY & HANDLING	14
2.1	TOOLS & INSTALLATION PREPARATION	14
2.2	PERSONAL PROTECTION EQUIPMENT (PPE)	15
2.3	SAFETY AND HANDLING	15
2.4	SITE CONSIDERATIONS	15
3	PACKAGING AND PRODUCT SPECIFICATIONS	16
4.	GREENZONE® PRODUCT REGISTRATIONS AND BUILDING CODE OF AUSTRALIA COMPLIANCE	19
INSTALLATION OF GREENZONE® PRODUCTS		20
GREENZONE® EXPANSION FOAM TERMITE SYSTEM		21
5.	TREATMENT OF SERVICE PENETRATIONS	21
5.1	GREENZONE® PRODUCTS FOR SERVICE PENETRATIONS	21
5.2	TYPICAL USES	21
5.3	SITE EVALUATION AND PREPARATION	22
5.4	INSTALLATION AROUND SINGLE SERVICE PENETRATIONS IN A TYPICAL CONCRETE SLAB –	22
5.5	SERVICE PENETRATIONS LOCATED WITHIN CONCRETE RIBS AND OR EDGE BEAMS	25
5.6	MULTIPLE PENETRATIONS	26
5.7	INSTALLATION AROUND SINGLE SERVICE PENETRATION IN A TYPICAL CONCRETE SLAB –	26
5.8	INSTALLATION AROUND SINGLE SERVICE PENETRATIONS IN A WAFFLE POD CONCRETE SLAB –	28
5.9	INSTALLATION AROUND SINGLE SERVICE PENETRATION IN CONCRETE SLAB – CAST IN DRAINAGE PITS	29
5.10	POST CONSTRUCTION APPLICATION OF TERMITE PAINT	30
6.	TREATMENT OF EXPANSION / CONTRACTION JOINTS	30
6.1	TYPICAL USES	30
6.2	GENERAL PREPARATION	31
6.3	WORK AREA PREPARATION	31
6.4	CONCRETE SLAB	32
6.5	EXTERNAL PERIMETER EXPANSION JOINT	32
6.6	CONCRETE PRECAST PANELS / INFILL SLAB / DOUBLE BRICK WALL	33
6.7	POST CONSTRUCTION APPLICATION OF BACKER ROD AND PAINT	34
7.	TREATMENT OF GREENZONE® EXPANSION FOAM TERMITE SYSTEM JOINTS AND JOINS	35
7.1	EXTERNAL AND INTERNAL CORNERS	35
7.2	END-TO-END JOINTS (BUTT JOINS)	37

GREENZONE® SOCK TERMITE SYSTEM 38

8. SERVICE PENETRATIONS	38
8.1 TYPICAL USES	38
8.2 GENERAL PREPARATION	38
8.3 INSTALLATION AROUND SINGLE SERVICE PENETRATIONS IN A TYPICAL CONCRETE SLAB	38
8.4 INSTALLATION METHOD FOR THE SIMPLE SLIDE-ON OPTION	39
8.5 INSTALLATION METHOD FOR FOLD OVER OPTION	41
8.6 GREENZONE INSTALLATION TO CONDUITS – PRIOR TO POUR	42

GREENZONE® PERIMETER TERMITE SYSTEM 43

9. GREENZONE® PERIMETER TERMITE SYSTEM	43
9.1 TYPICAL USES	43
9.2 GENERAL PREPARATION	44
9.3 GENERAL INSTALLATION OF GREENZONE® PERIMETER TERMITE SYSTEM	44
9.4 TYPICAL INSTALLATION DETAILS – GREENZONE® PERIMETER TERMITE SYSTEM	45
9.5 GREENZONE® PERIMETER TERMITE SYSTEM – JOINS AND REPAIRS	47
9.6 TERMITE PROTECTION TO CONCRETE SLAB JOINTS	48
9.7 TERMITE PROTECTION TO SAW CUTS	49
9.8 GREENZONE® PERIMETER TERMITE SYSTEM – EXTERNAL CORNER DETAIL	50
9.9 GREENZONE® PERIMETER TERMITE SYSTEM – INTERNAL CORNER DETAIL	50
9.10 GREENZONE® EXTERNAL PERIMETER CORNER	52
9.11 GREENZONE® INTERNAL PERIMETER CORNER	52

GREENZONE® TERMITE PAINT SYSTEM 53

10. GREENZONE® TERMITE PAINT SYSTEM	53
10.1 TYPICAL USES	53
10.2 SITE & SURFACE PREPARATION	54
10.2 GENERAL APPLICATION OF GREENZONE® PAINT	56

GREENZONE® BACKER ROD 58

11. GREENZONE® BACKER ROD SYSTEM	58
11.1 TYPICAL USES	58
11.2 SITE & SURFACE PREPARATION	59
11.3 GENERAL INSTALLATION OF GREENZONE® BACKER ROD	59
12. GREENZONE® ACCESSORIES	60
12.1 WARNING TAPE (REMOVABLE COVER FROM SELF-ADHESIVE STRIP)	60
12.2 WARNING TAPE (SELF ADHESIVE)	60
13. GREENZONE® MAINTENANCE & REPAIRS	61
13.1 REPAIRS AND PATCHING	61
14. GREENZONE® MAINTENANCE, WARRANTY & REGISTRATION	62
14.1 WARRANTY & REGISTRATION	62



1. INTRODUCTION

Green Zone Pty Ltd is a privately-owned Australian company supplying innovative pest control management systems for the Australian pest control market.

The product range:

- GREENZONE® Expansion Foam Termite System
- GREENZONE® Sock Termite System
- GREENZONE® Perimeter Termite System
- GREENZONE® Backer Rod
- GREENZONE® Termite Paint
- GREENZONE® Primer
- GREENZONE® Sealant
- GREENZONE® Bifenthrin
- GREENZONE® Fipronil
- Altis Pro Reticulation System

These products are suitable for use across Australia and are available for purchase through major pest control product suppliers throughout Australia.

In all instances our GREENZONE® products work in conjunction with the concrete slab being poured to AS 2870.2011 (or) AS 3600:2018 which form an integral part of the termite risk management measure by using the concrete slab as a physical barrier complying with AS 3660.1-2014 Section 4.4.



1.1 GREENZONE® TERMITE AND INSECT MANAGEMENT PRODUCTS

GREENZONE® Expansion Foam Termite System (See section 5)

GREENZONE® Expansion Foam Termite System is an innovative, patented, closed cell, cross-linked, polyethylene compressible foam containing Bifenthrin.

It is suitable for use as any one of the following applications:

- GREENZONE® Termite System (GTS),
- GREENZONE® Insect Barrier (GIB),
- GREENZONE® Expansion Joint Filler (GEJF).

The core innovation is the integration of a termite repellent into expansion joint foam which can be applied to all elements of construction that require a termite barrier in order to comply with the relevant termite risk management sections of the Building Code of Australia.

GREENZONE® Expansion Foam Termite System is a polyethylene expansion joint foam containing Bifenthrin to act as a barrier to termites, black ant and cockroaches. Bifenthrin is a pyrethroid insecticide and termiticide, a 4th generation pyrethroid, which is virtually insoluble in water and the longest residual termiticide currently registered on the market. Bifenthrin is a product used worldwide and is common in pesticides and termiticides.



GREENZONE® Expansion Foam Termite System

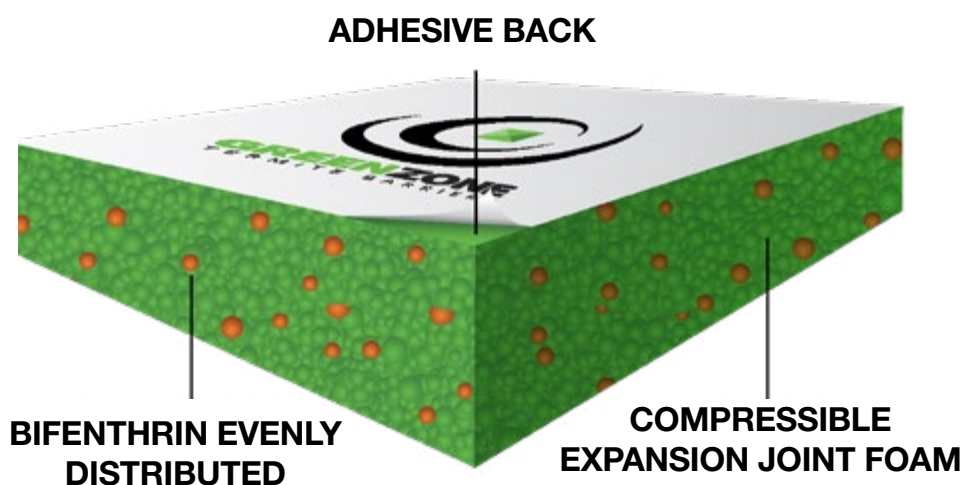

GREENZONE® Sock Termite System (See section 8)

Utilising the GREENZONE® Expansion Foam Termite System technology, the GREENZONE® Sock Termite System is an innovative, patented, closed cell, cross-linked, polyethylene compressible foam, supplied in a sock form, containing Bifenthrin.

The GREENZONE® Sock Termite System is a slide on/over that is used on service penetrations. They are 'folded back' on themselves and comply to AS 3660.1,2014.5.3.6 – concrete slab penetrations (Figure 5.3 B (pre - pour)).



GREENZONE® Sock Termite System

GREENZONE® Perimeter Termite System (See section 9)

GREENZONE® Perimeter Termite System is a physical termite risk management measure that is flexible in nature. It is classified in AS 3660.1,2014 as a sheet material. GREENZONE® Perimeter Termite System is a once only treatment that is designed to last the economical life of the building.

GREENZONE® Perimeter Termite System is installed to areas of the building where termites may ingress. The GREENZONE® Perimeter Termite System is designed to force out the undetected entry of termites where their earthen tunnels and galleries are readily detected.



GREENZONE® Perimeter Termite System

GREENZONE® Termite Paint System (See section 10)

GREENZONE® Termite Paint System is an acrylic sealant paint combined with Bifenthrin which can be applied to a variety of surfaces using a variety of methods including a brush and roller or with a caulking gun. It may also be used in conjunction with our Expansion Foam and Backer Rod products.

The GREENZONE® Termite Paint System includes a Primer and Paint. It is classified in AS 3660.1,2014 as a Chemical Barrier. GREENZONE® Termite Paint System must be used to form a continuous barrier that while flexible will still block termite passage in a long lasting manner.



GREENZONE® Termite Paint System

In particular, the GREENZONE® Termite Paint System is also an effective remedy in situations where a chemical or physical barrier has not been applied prior to pouring concrete.

GREENZONE® Backer Rod (See section 11)

GREENZONE® Backer Rod is an innovative, patented, closed cell, cross-linked, polyethylene compressible foam containing Bifenthrin in a circular tube.

It is suitable for use as any one of the following applications:

- GREENZONE® Termite System (GTS),
- GREENZONE® Insect Barrier (GIB),
- GREENZONE® Expansion Joint Filler (GEJF).

The Backer Rod product is made from the same foam integrated with Bifenthrin that is used in our Expansion Joint product.

Backer Rod can be used to prevent the ingress of pests including but not limited to cockroaches, ants and termites through openings around windows, doors and in certain construction joints. It can also complement the use of the GZ termite Paint System as it can be used as a gap filler for large crevices and cracks prior to the application of the Termite Paint.



GREENZONE® Backer Rod

GREENZONE® Bifenthrin

GREENZONE® Bifenthrin is a repellent termiticide that will prevent and control subterranean termite infestations inside and outside of domestic and commercial structures.

The diluted termiticide is sprayed directly into the soil or drilled through concrete and then pumped into the earth to create a barrier between the building and the termites.



GREENZONE® Bifenthrin

GREENZONE® Fipronil

GREENZONE® Fipronil is a non-repellent termiticide and insecticide for the control of subterranean termites and ant infestations.

GREENZONE® Fipronil protects structures from termite damage by forming a continuous chemically-treated zone.

This product is used for external applications across domestic, commercial, public and industrial buildings/structures. GREENZONE® Fipronil is also highly effective for controlling ants through direct contact and residual activity on treated surfaces.



GREENZONE® Fipronil

Altis Pro Termite Reticulation System

Altis Pro is a patented Termite Reticulation System designed to effectively treat the area under concrete slabs, for protection against infestation by subterranean termites.

Altis Pro Reticulation System can achieve remarkable accuracy in the delivery of chemicals and create a complete perimeter barrier from a single pump-up point. The flexible 'emitter' ribbon (also known as pipe, tape or dripper line) ensures the correct amount of chemical is equally delivered to all areas treated over a 100m distance from one central pump-up station.

Product Benefits:

- Easy to install
- Easily connected with slip joints
- Reliable Protection
- Clog-resistant membrane
- Single point fill efficiency

Greenzone Bifenthrin and Greenzone Fipronil are the recommended chemicals to use.



Altis Pro Reticulation System

1.2 APPLICATIONS

GREENZONE® can be used across many different applications within the residential, commercial and industrial building and construction segments. There are five main categories:

1) Service Penetration Applications

GREENZONE® Expansion Foam Termite System (EFTS) is used as an expansion foam around pipe penetration in concrete slab construction. By using GREENZONE® EFTS the need to install a secondary termite collar barrier is removed. GREENZONE® EFTS provides both termite protection and addresses the expansion/contraction of concrete around penetrations in one-step.

Service penetrations can be protected by using either the GREENZONE® EFTS, wrapped around the penetrations (as per figure 1.2A) or for 100 mm and 50 mm pipes (nominal sizes) the GREENZONE® Sock Termite System can be used (as per figure 1.2 B) or folded back on itself as indicated in Figures 8.5 B and 8.5 C on page 35.

The GREENZONE® Paint System can also be used where the concrete slab has been poured and the installation of a termite system has been omitted. This is applied as a paint around the base of the Penetration.

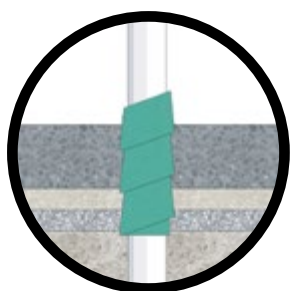

FIGURE 1.2 A

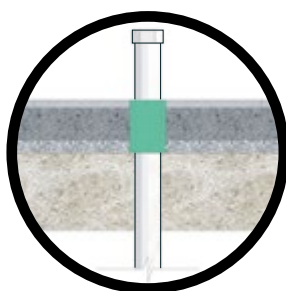

FIGURE 1.2 B



FIGURE 1.2 C

2) Expansion and Contraction Joint Applications

GREENZONE® EFTS and BR are used as an expansion foam in control joints required in concrete slab construction. By using GREENZONE® EFTS the need to install a secondary termite fabric barrier is removed.

GREENZONE® EFTS & BR provides both termite protection and addresses the expansion/contraction of concrete slabs in one-step (see figure 1.2 D). Both the EFTS and BR may also be used in conjunction with the GREENZONE® Termite Paint (TS) to create a continuous, flexible physical termite and insect barrier (figures 1.2 E & 1.2 F).

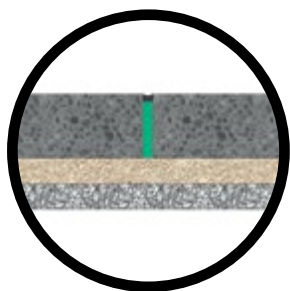

FIGURE 1.2 D

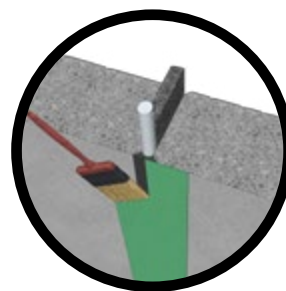

FIGURE 1.2 E



FIGURE 1.2 F



GREENZONE®

3) Concrete Infill Slab Applications

GREENZONE® EFTS is used as an expansion foam in control joints required where concrete infill slabs abut a concrete or brick wall. By using GREENZONE® EFTS the need to install a secondary termite fabric barrier is removed. GREENZONE® EFTS provides both termite protection and addresses the expansion and contraction of concrete infill slabs.

The GREENZONE® Paint and Backer Rod products may also be used in a post construction context where a pre-construction termite system was omitted to create a compliant installation system. (see figure 1.2 H).



FIGURE 1.2 G



FIGURE 1.2 H

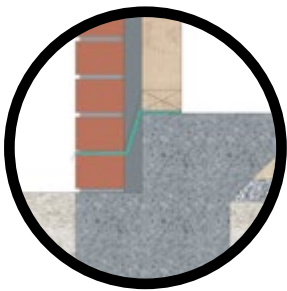

FIGURE 1.2 I

4) Building Perimeter

GREENZONE® Perimeter Termite System is a physical termite risk management measure that is flexible in nature. It is classified in AS 3660.1,2014 as a sheet material. It is a once only treatment that is designed to last the economical life of the building (see figure 1.2 I).



FIGURE 1.2 J

5) Building Openings

GREENZONE® Backer Rod is a chemical barrier to prevent and deter the ingress of insects via building openings such as windows, doors, skylights, voids around horizontal pipe penetrations among others.

1.3 GREENZONE® FEATURES & BENEFITS

Why use GREENZONE®?

- ✓ GREENZONE® EFTS is a termite and insect system product integrated within a compressible foam substrate suitable for use as an expansion joint filler,
- ✓ No need for two products - GREENZONE® EFTS is one-product – one-step installation process, saves time and money,
- ✓ No need to engage separate trades to install termite barriers and expansion jointing – GREENZONE® EFTS does both,
- ✓ GREENZONE® reduces the need to use chemical sprays on site, a benefit to the environment,
- ✓ GREENZONE® EFTS is an Australian invention which remains wholly Australian owned,
- ✓ GREENZONE® products improve environmental health outcomes by preventing termite infestation in the first instance,
- ✓ GREENZONE® products are all suitable for commercial and industrial applications,
- ✓ GREENZONE® EFTS adds value to the treatment of masonry contraction and expansion joints – with a termite and insect barrier,
- ✓ Increasing regulatory interest in environmentally efficient products that reduce resource use and prevent pest infestation,
- ✓ GREENZONE® has a comprehensive product range including complementary products that ensure installers are able to flexibly respond to new construction requirements.

1.4 GENERAL APPLICATIONS

The following are examples of where the GREENZONE® Termite System can be used.



✓ Residential



✓ Commercial

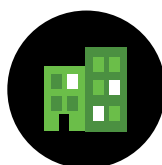

✓ Offices



✓ Hospitals & Health Care



✓ Retail

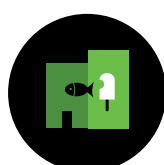

✓ Food Storage/
Warehousing



✓ Cafes & Restaurants



✓ Supermarkets

1.5 INTELLECTUAL PROPERTY

The GREENZONE® Termite System technology is protected by patent in Australia, United States of America, Singapore, China and Europe.



GREENZONE®

2 TOOLS, PPE, SAFETY & HANDLING

2.1 TOOLS & INSTALLATION PREPARATION

The installation of GREENZONE® is very simple, requiring only a small number of tools. The following are the mostly commonly used tools:

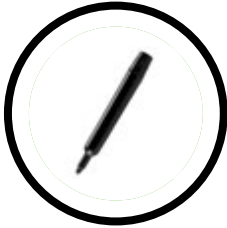

Black Marker



Retractable Blade Knife



Heavy Duty Scissors



GREENZONE® Warning Tape



3M Spray Adhesive (or similar)



Measuring Tape



Chalk Line



Chaulking Gun



Nail Gun & Pins



Clear Tape



Cable Ties



Spatula



Paint Brushes



Blower



Broom



Sandpaper



Wire Brush



Construction Adhesive

2.2 PERSONAL PROTECTION EQUIPMENT (PPE)

General:

In addition to the use of standard PPE, when using GREENZONE® products, wear heavy duty nitrile disposable gloves.

A suitable alternative is to also wear elbow length chemical resistant gloves however these require management after use including washing and appropriate storage.

All uniforms or clothing worn during installation should be regularly and separately washed from household washing.

Personal Hygiene:

Wash hands and arms before eating, drinking or smoking.



2.3 SAFETY AND HANDLING

The GREENZONE® products shall be stored in a dry, well-ventilated area, free from direct sunlight at normal temperatures. The suggested range of normal temperatures is no less than 5 degrees and up to 40degrees Celsius).

GREENZONE® Termite Paint & Primer has a shelf life of 12 months. It must be retained and stored in its original container for this to apply.

Once opened it must be used or disposed of within 3 months. Mark containers when opened to ensure tracking. All excess offcuts of GREENZONE® are to be properly disposed of.

For any additional information please contact Green Zone Pty Ltd directly on 03 9555 7876 or info@greenzonebarrier.com.

2.4 SITE CONSIDERATIONS

Prior to applying or installing any GREENZONE® product, the installer should have already undertaken all general site safety, access and general safe work method assessments and measures.

The installer should inspect the area of proposed application to determine that the treatment will create a continuous and compliant termite barrier that deters concealed entry of termites.

The installer should consult with the builder about the correct order of scheduled works and that all works have been completed to the necessary stage or level to facilitate the creation of a continuous compliant barrier.

The installer should also consult with the builder regarding the proposed use of the products, the substrate surfaces the product will be applied to and the upcoming works to ensure compliance with the Australian Standard and to protect the barriers created after installation or application.

Any fixings installed or applied to Greenzone products should bear their own weight or have additional supporting structures to ensure that the Greenzone products are not bearing load.

Materials applied must not stress, stretch or cause the Greenzone barrier to move or degrade.

Any holes or penetrations made to fix materials to Greenzone products must also be treated in line with the guidelines below. Failure to treat these penetrations will create an unplanned untreated termite entry point.

All materials used for fixings must be termite resistant and corrosion proof ie stainless steel. Any glues must be water based solvents and silicones may not be used.



GREENZONE®

3 PACKAGING AND PRODUCT SPECIFICATIONS

GREENZONE® EXPANSION FOAM TERMITE SYSTEM



Available in packs of 2 x 25m rolls at 10mm thick x 100mm wide – Total 50LM per pack. Product is supplied in off-white and grey colour.



GREENZONE® SOCK TERMITE SYSTEM

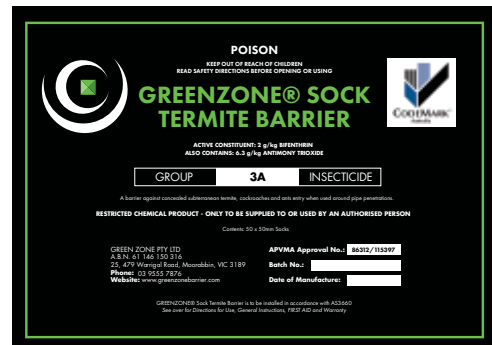

GREENZONE® Socks are available to suit five nominal pipe sizes: 25mm, 40mm, 50mm, 80mm and 100mm.

Socks are generally sold in packs of 25 in boxes of 100.



GREENZONE® PERIMETER TERMITE SYSTEM



Available in 50LM long rolls in sizes: 100mm, 150mm, 200mm, 250mm, 300mm, 1200mm and 4000mm.

Product is supplied in off-white colour.

GREENZONE® GREENZONE INTERNAL PERIMETER CORNER



GREENZONE® GREENZONE EXTERNAL PERIMETER CORNER



GREENZONE®

GREENZONE® TERMITE PAINT SYSTEM

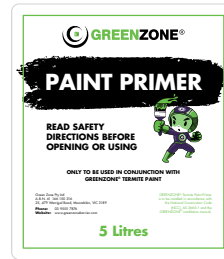

Paint available in 15 L Drum and as a 330 mL Caulking Cartridge and is grey in colour.

Paint Primer available in a 5 L bottle.

GREENZONE® BACKER ROD

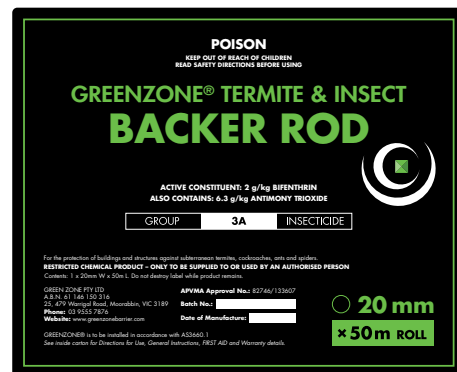

50 LM Carton in continuous coil tube format.

4. GREENZONE® PRODUCT REGISTRATIONS AND BUILDING CODE OF AUSTRALIA COMPLIANCE

All GREENZONE® products have been approved for use by the Australian Pesticides and Veterinary Medicines Authority (APVMA). For further information on APVMA go to www.apvma.gov.au.

GREENZONE® Expansion Foam and GREENZONE® Socks (CM20133) and GREENZONE® Perimeter System (CM20281) are CodeMark compliant.



The Codemark Certification Scheme is a voluntary third-party building product certification scheme that authorises the use of new and innovative products in specified circumstances in order to facilitate compliance with Volumes One and Two of the National Construction Code (NCC), also known as the building Code of Australia (BCA).

CodeMark provides confidence and certainty to regulatory authorities and the market through the issue of a Certificate of Conformity, which is one of several options available for meeting the 'evidence of suitability' requirements of the BCA.

For further information on CodeMark go to <https://www.abcb.gov.au/Product-Certification/CodeMark-Certification-Scheme>

For further details on GREENZONE products registrations with the APVMA and CodeMark please visit our website www.greenzonebarrier.com



INSTALLATION OF GREENZONE® PRODUCTS



GREENZONE® EXPANSION FOAM TERMITE SYSTEM



5. TREATMENT OF SERVICE PENETRATIONS

GREENZONE® Expansion Foam Termite System (EFTS) and GREENZONE® Sock Termite System can be installed around service penetrations in masonry structures, e.g. concrete slabs, concrete walls, block and brick walls. GREENZONE® EFTS acts as a physical termite and insect barrier and provides a compressible foam joint for the contraction and expansion of masonry elements.

5.1 GREENZONE® PRODUCTS FOR SERVICE PENETRATIONS

There are two GREENZONE® products suitable for use around service penetrations. They are:

- GREENZONE® Expansion Foam Termite System (100 mm wide x 10 mm thick in 25 m rolls, 200 mm wide x 10 mm thick in 25m roll)
- GREENZONE® Sock Termite System (suit nominal 40 mm, 50 mm, 80 mm and 100 mm diameter pipes).
- GREENZONE® Paint System
- GREENZONE® Backer Rod

5.2 TYPICAL USES

GREENZONE® is suitable for use generally in these areas:

- Around Plumbing Pipes – Drains, Sanitary, Water, Gas,
- Around Electrical Conduits,
- Around other Service Penetrations – e.g. HVAC, Drains, Vents, Access hatches, etc.

5.3 SITE EVALUATION AND PREPARATION

Before commencing work on site a general site inspection should be undertaken to determine if the site contains any signs of termites. If termites are located on the site, the installer needs to take the necessary steps to remove the termites and their nest prior to commencing work. Refer to AS 3660.1: 2014 (page 68) Appendix F / BUILDING SITE MANAGEMENT (Normative)

Ensure the surface (i.e. surface to which GREENZONE® EFTS will be applied) of the fixed element of the expansion joint is clean and free of dirt, grease, oil and release residues etc.

NOTE

Installation as shown on the following Figures: 5.4 A; 5.4 B; 5.4 C; 5.4.D; 5.4 F; 5.5 A; 5.5 B; 5.6 A; 5.7 A; 5.7 B; 5.8.A (pages 15-21) all comply to AS 3660.1: 2014. Option B and C (Pre-Pour) – with a minimum of 15 mm width cast into the slab. These are referred as ‘a wrap’.

FOR ALTERNATIVE PROTECTION OPTIONS TO SERVICE PENETRATIONS REFER TO THE ‘GREENZONE® SOCK TERMITE SYSTEM’ SECTION (pages 36–40).

5.4 INSTALLATION AROUND SINGLE SERVICE PENETRATIONS IN A TYPICAL CONCRETE SLAB –

METHOD FOR INSTALLATION BEFORE FORMWORK IS SET UP

STEP ONE

1. Clean pipe with appropriate tool(s) to ensure that the pipe is smooth, is free of dirt, concrete, adhesives, grease, oil and the like, is dry and is free of any other defect (e.g. split, break, puncture or divot).
2. Establish approximate height of finished concrete and the thickness of the concrete slab (A):
 - a. Mark on the service penetration the finished concrete slab height (B),
 - b. Mark on the service penetration the underside position of the concrete slab (C).

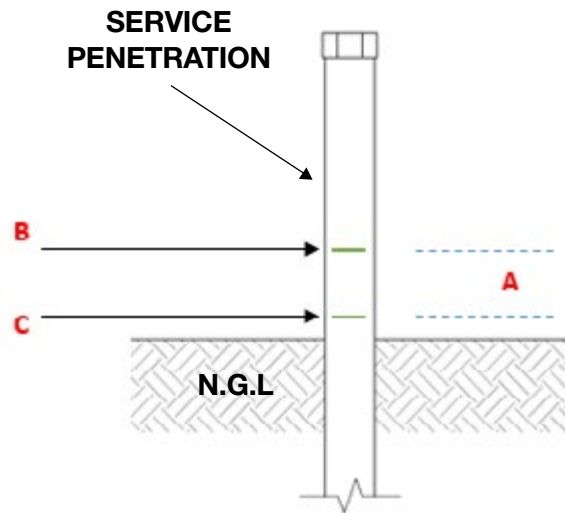

FIGURE 5.4 A

When applying GREENZONE® EFTS, ensure that GREENZONE® EFTS extends at least 50mm above the mark at (B) and at least 100mm below the mark at (C) – or to N.G.L, whichever is lesser around the penetration.

STEP TWO

1. Starting from the bottom of the service penetration, apply GREENZONE® EFTS to the base (i.e. where the service penetrates the sand/soil base) or at least 100mm below the underside position of the concrete slab:
 - a. peel off a section of the protective coating to the self-adhesive backing and place a section of the GREENZONE® EFTS on the pipe, making sure the 10mm zip-strip is facing up,
 - b. then wrap horizontally once in a circular motion to ensure the GREENZONE® EFTS fully covers the external perimeter of the pipe,
 - c. then continue to wrap the pipe in a circular motion angled upwards at approximately 22 degrees (see figure 5.4 B) ensuring that the GREENZONE® EFTS has a minimum lap of 20mm and continue until the wrap exceeds the height of the finished concrete slab by a minimum of 100 mm.
 - d. as the GREENZONE® EFTS is applied to the pipe ensure that there are no kinks, rips, tears or defects in the material – (if any of these are found in the material please refer to section 10.4 on repairs etc.) – also apply sufficient pressure to ensure that the GREENZONE® EFTS is securely stuck to the pipe and that there are no air bubbles or voids between the pipe and the GREENZONE® EFTS.

2. To finish, cut the GREENZONE® EFTS neatly with a sharp knife or scissors and press the GREENZONE® EFTS to ensure complete adhesion to the pipe.
3. Once the GREENZONE® EFTS has been securely attached to the penetration, use the paper backing removed from the adhesive side of the GREENZONE® EFTS to wrap the top section of the penetration, using a clear tape to secure it to the penetration. (See Figure 5.4 D).

This will assist in notifying other trades people on site that GREENZONE® EFTS has been installed. Refer to section 10.1 for more details on the GREENZONE® warning tape. (See figure 5.4 C).

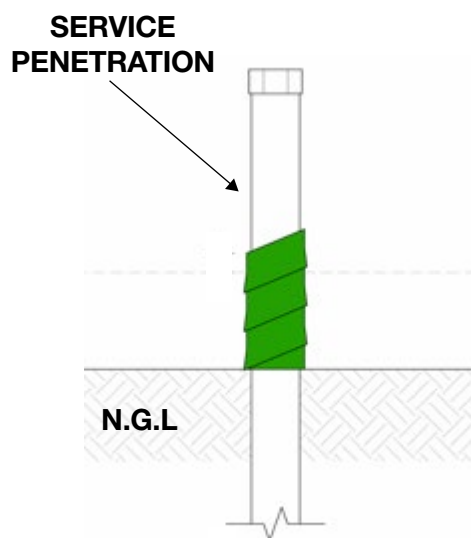

FIGURE 5.4 B

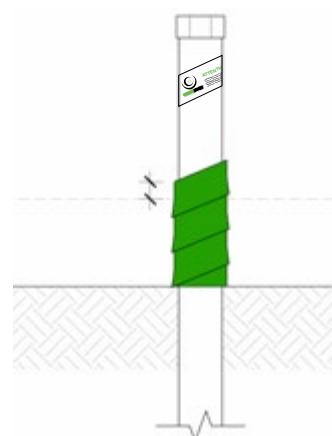

FIGURE 5.4 C

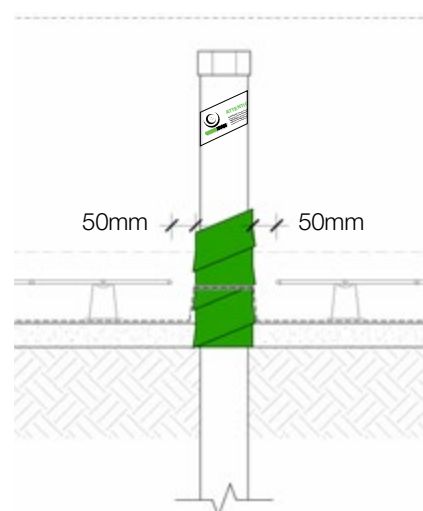

FIGURE 5.4 D



GREENZONE®

IMPORTANT NOTES TO CONCRETER

- The placement of any reinforcement mesh and bar chairs should not be closer than 50mm to GREENZONE®. (See Figure 5.4 D).
- The plastic membrane shall be neatly cut around the service penetration and secured over GREENZONE® EFTS with appropriate tape. The plastic membrane and tape should be positioned a minimum of 50mm from the finished height of the concrete slab. (See Figure 5.4 D).

On completion of concreting

1. Once the concrete has been poured and cured, any excess GREENZONE® EFTS around the service penetration should be removed. (See figure 5.4 E).
2. To remove, using a sharp knife, cut the GREENZONE® EFTS around the penetration at the height of the finished floor level. (See figure 5.4 F).
3. Any gaps, voids, holes between the service penetration GREENZONE® EFTS should be filled with suitable termiticide sealant, e.g. Termiflex.

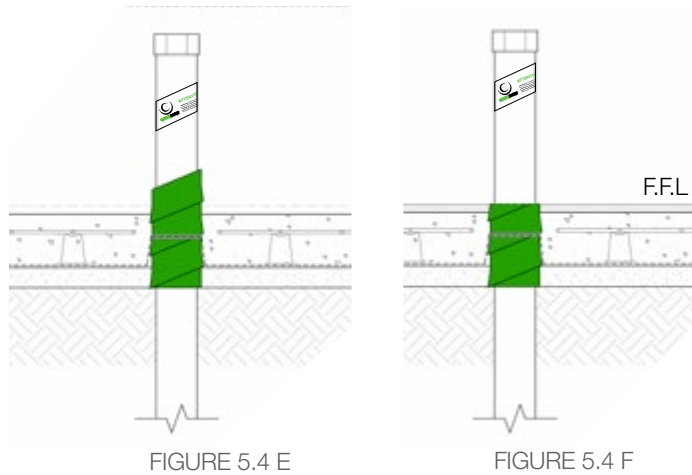

NOTE

20 mm overlaps results in a minimum of 15 mm cast horizontally into the slab as required in AS 3660.1,2014. 5.3.6 – Concrete slab penetrations (Figure 5.4 G (Pre-pour)).



FIGURE 5.4 G

5.5 SERVICE PENETRATIONS LOCATED WITHIN CONCRETE RIBS AND OR EDGE BEAMS

When service penetration(s) are located within internal ribs and or external edge beams of a concrete slab, installation of the GREENZONE® EFTS is undertaken in a similar method to the single penetration (Refer to Section 5 for details) - with these additions:

STEP 1

1. Ensure that the full length of the pipe, which is to be encased in concrete, is wrapped with GREENZONE® EFTS (See figure 5.5 A) that is, from the point where the pipe penetrates the sand/soil or plastic membrane, continuing until the GREENZONE® EFTS wrap exceeds the height of the finished concrete slab by a minimum of 100mm.
2. As the pipe is wrapped, ensure that the GREENZONE® EFTS overlaps itself by at least 20mm – GREENZONE® EFTS is to be applied continuously around any fittings and or connections to ensure a consistent coverage to the pipe is achieved,
3. Figure 5.5 B shows the GREENZONE® EFTS wrapping the service penetration following the completion of the concrete pour, prior to the excess being cut and removed.
4. **NOTE:** If during the wrapping of a penetration, the GREENZONE® EFTS needs to be joined:
 - using a sharp knife or scissors neatly cut the end of the GREENZONE® EFTS on the penetration – on the new roll of GREENZONE® EFTS neatly cut the end – butt join the two pieces and continue to wrap the penetration.
5. Once the GREENZONE® EFTS has been securely attached to the penetration, use the paper backing removed from the adhesive side of the GREENZONE® EFTS to wrap the top section of the penetration, using a clear tape to secure it to the penetration. (See Figure 5.5 B) Refer to section 10.1 for more details on the GREENZONE® warning tape.

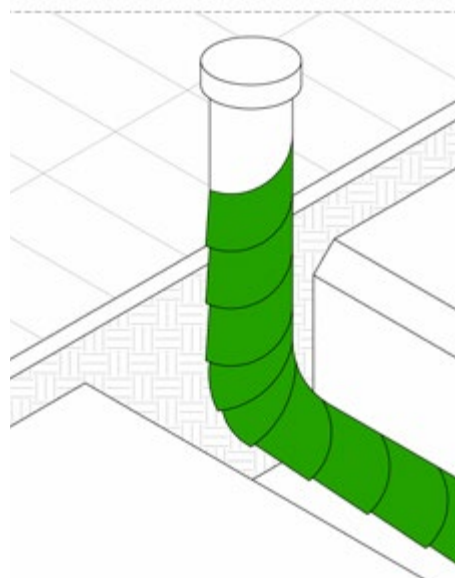

FIGURE 5.5 A

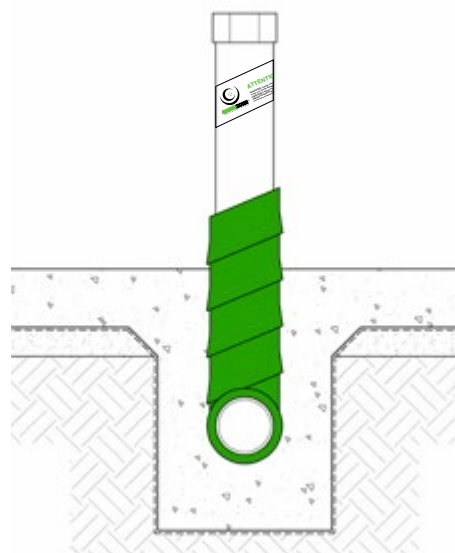

FIGURE 5.5 B



GREENZONE®

5.6 MULTIPLE PENETRATIONS

1. Installation of GREENZONE® EFTS around multiple penetrations is undertaken in the same method as single penetrations. (Refer to Section 5.4 for details)

NOTE: Where several individual service penetrations are located, or grouped in close proximity to each other, each penetration shall be wrapped in GREENZONE® EFTS (See figure 5.6 A). Each penetration must also have its own warning tape label secured (See figure 10.1 B). This process is the same as explained in Section 5.4. Refer to section 10.1 for more details on the GREENZONE® warning tape.

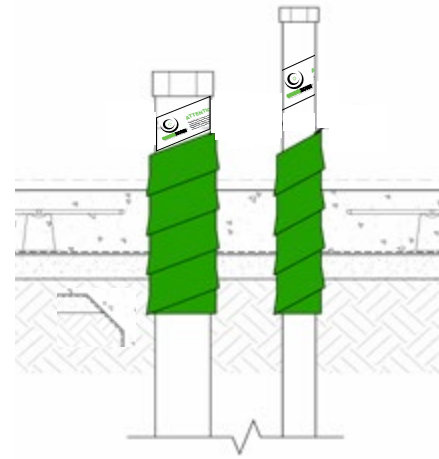

FIGURE 5.6 A

5.7 INSTALLATION AROUND SINGLE SERVICE PENETRATION IN A TYPICAL CONCRETE SLAB –

AFTER CONCRETE HAS SETUP FORMWORK AND REINFORCEMENT MESH IS PLACED

STEP 1

1. Clean pipe with appropriate tool(s) to ensure that the pipe is smooth, is free of dirt, concrete, adhesives, grease, oil and the like, is dry and is free of any other defect (e.g. split, break, puncture or divot),
2. Starting from the bottom of the service penetration, apply GREENZONE® EFTS to the base (i.e. where the service penetrates the moisture barrier):
 - a. peel off the protective coating to the self-adhesive backing and place a section of the GREENZONE® EFTS on the pipe, making sure the 10mm zip strip is facing up,
 - b. then wrap horizontally once in a circular motion to ensure GREENZONE® EFTS fully covers the external perimeter of the pipe and is firmly pressed against the moisture barrier,
 - c. then continue to wrap the pipe in a circular motion angled upwards at approximately 22 degrees (see figure 5.7 A) ensuring that the GREENZONE® EFTS has a minimum lap of 20mm and continue until the wrap exceeds the height of the finish floor by a minimum of 40mm at the lowest point,

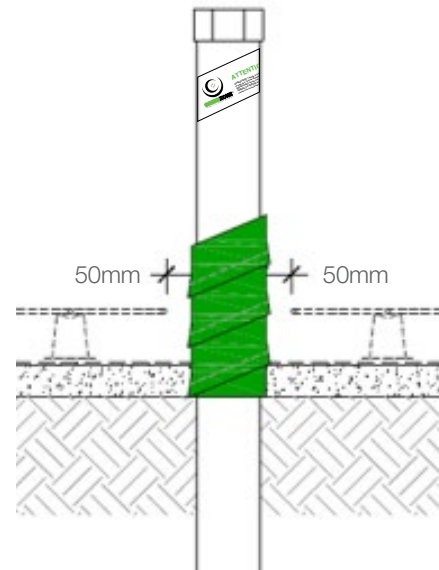

FIGURE 5.7 A

- d. as the GREENZONE® EFTS is applied to the pipe ensure that there are no kinks, rips, tears or defects in the material – (if any of these are found in the material please refer to section 10.4 on repairs etc.) – also apply sufficient pressure to ensure that the GREENZONE® EFTS is securely stuck to the pipe and that there are no air bubbles or voids between the pipe and the GREENZONE® EFTS.
3. Cut the GREENZONE® EFTS neatly with a sharp knife or scissors and press the GREENZONE® EFTS to ensure complete adhesion to the pipe.
4. Once the GREENZONE® EFTS foam has been securely attached to the penetration, use the paper backing removed from the adhesive side of the GREENZONE® EFTS to wrap the top section of the penetration, using a clear tape to secure it to the penetration. (See Figure 5.7 B) Refer to section 10.1 for more details on the GREENZONE® warning tape.

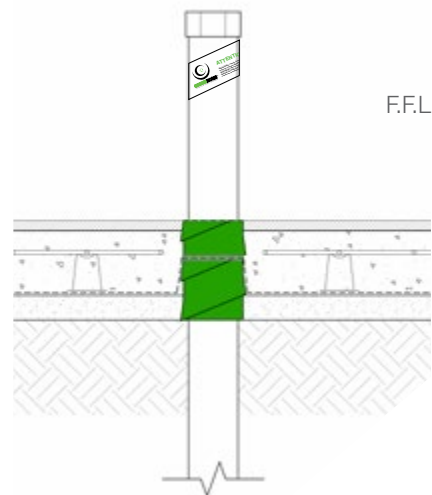

FIGURE 5.7 B

STEP 2 – ON COMPLETION

1. Once the concrete has been poured and cured, any excess GREENZONE® EFTS should be removed.
2. To remove, using a sharp knife, cut the GREENZONE® EFTS around the penetration at the height of the finished floor level. (See figure 5.7 B)
3. Any gaps, voids, holes, between the service penetration and the GREENZONE® EFTS shall be filled with suitable termiticide sealer, e.g. Termiflex.



Individually wrapped pipe penetrations shown, with warning tape after concrete has been poured.

5.8 INSTALLATION AROUND SINGLE SERVICE PENETRATIONS IN A WAFFLE POD CONCRETE SLAB –

AFTER CONCRETER HAS SETUP FORMWORK, PLACED THE WAFFLE PODS AND REINFORCEMENT MESH

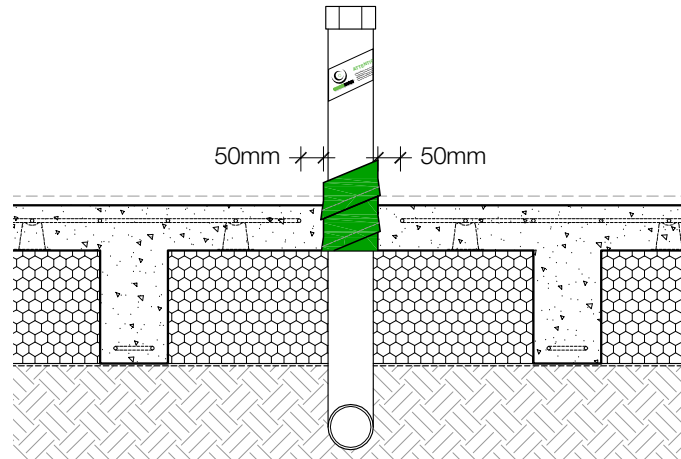

FIGURE 5.8 A

STEP 1

1. Starting from the bottom of the service penetration, apply GREENZONE® EFTS to the base (i.e. where the service penetrates the waffle pod):
 - a. peel off the protective coating to the self-adhesive backing and place a section of the GREENZONE® EFTS on the pipe, making sure the 10mm zip strip is facing up,
 - b. then wrap horizontally once in a circular motion to ensure GREENZONE® EFTS fully covers the external perimeter of the pipe and is firmly pressed against the moisture barrier,
 - c. then continue to wrap the pipe in a circular motion angled upwards at approximately 22 degrees (see figure 5.8 A) ensuring that the GREENZONE® EFTS has a minimum lap of 20mm and continue until GREENZONE® EFTS wrap exceeds the height of the concrete floor by a minimum of 100mm,
 - d. as the GREENZONE® EFTS is applied to the pipe ensure that there are no kinks, rips, tears or defects in the material – (if any of these are found in the material please refer to section 10.4 on repairs etc.) – also apply sufficient pressure to ensure that the GREENZONE® EFTS is securely stuck to the pipe and that there are no air bubbles or voids between the pipe and the GREENZONE® EFTS.
2. Cut the GREENZONE® EFTS neatly with a sharp knife or scissors and press the GREENZONE® EFTS to ensure complete adhesion to the pipe.
3. Once the GREENZONE® EFTS has been securely attached to the penetration, use the paper backing removed from the adhesive side of the GREENZONE® EFTS to wrap the top section of the penetration, using a clear tape to secure it to the penetration. (See Figure 5.8 A) Refer to section 10.1 for more details.

NOTE: A minimum gap of 50mm is required from the edge of the GREENZONE® EFTS to any reinforcement mesh or bar chairs. (See figure 5.8 A). Refer also to waffle pod supplier installation information and or seek engineering advice.

5.9 INSTALLATION AROUND SINGLE SERVICE PENETRATION IN CONCRETE SLAB – CAST IN DRAINAGE PITS

When using GREENZONE® EFTS around other penetrations in concrete slab construction, the following is an example of how a penetration in a concrete slab (requiring termite and or insect barrier protection) may be addressed for expansion and contraction.

1. Using the appropriate tool(s), clean the surface to which the GREENZONE® EFTS will be adhered so that it is smooth, is free of dirt, concrete, adhesives, grease, oil and the like, is dry and is free of any other defect (e.g. split, break, puncture or divot),
2. Measure the outside perimeter of the drainage pit and using a sharp knife cut the GREENZONE® EFTS to the length required. NOTE: GREENZONE® EFTS cannot be applied in a continuous strip around internal and external corners – it must be cut and neatly joined on the external corners (See figure 5.9 B)

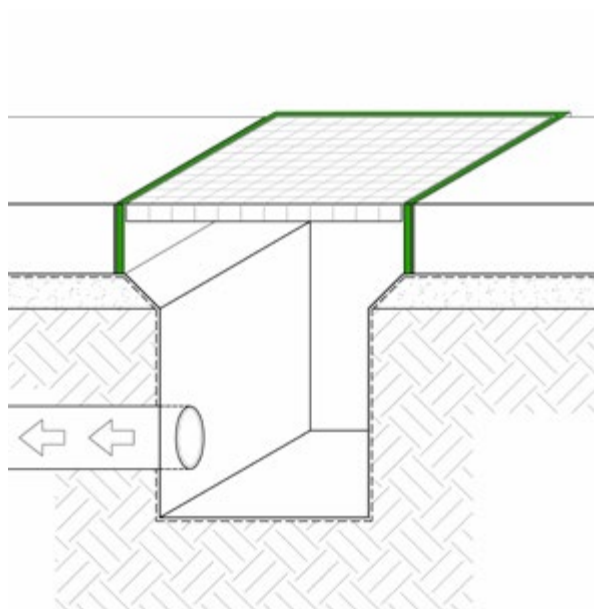

FIGURE 5.9 A

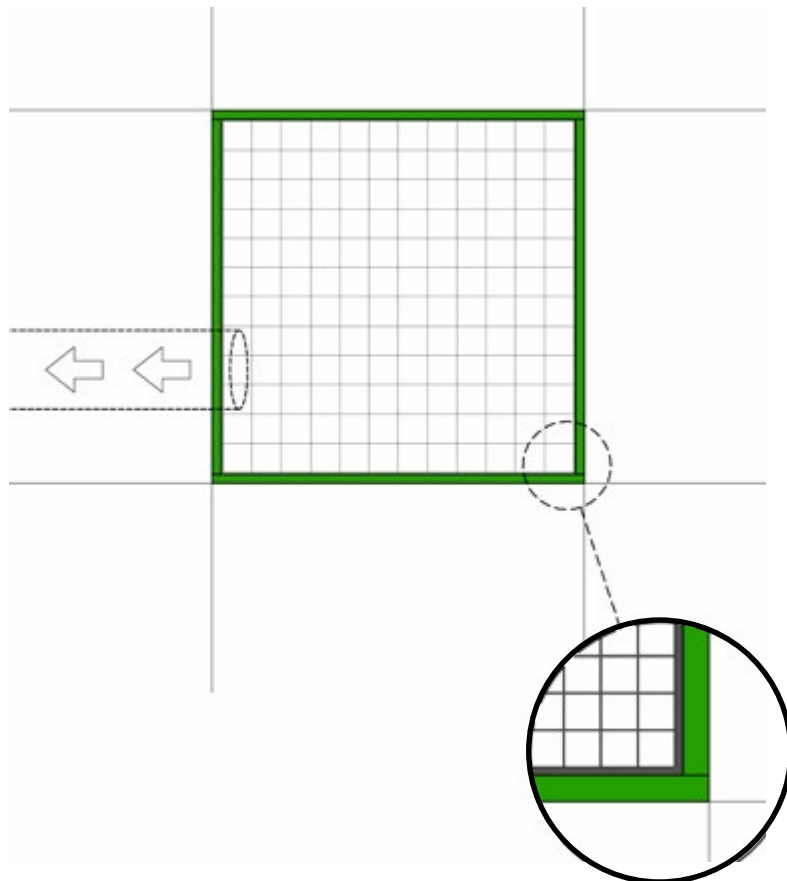

FIGURE 5.9 B

5.10 POST CONSTRUCTION APPLICATION OF TERMITE PAINT

In situations where a compliant barrier has been omitted prior to pouring concrete, the installer can follow this procedure using BR and Paint to create a compliant barrier.

1. Clear any excess concrete debris, dirt or other materials from the affected area.
2. Rough up the pvc pipe with sandpaper and or wire brush to lightly abrade the surface and remove concrete dags to improve adhesion.
3. Apply Primer or Adhesive Spray thoroughly before backer rod is installed.
4. Insert backer rod, requires where possible to remove the top layer of expansion joint if present or plastic, fill any cracks or crevices 15mm or more should have backer rod pressed firmly into fill the cracks or crevices.
5. Apply the paint (2 coats) as per Termite Paint instructions.

6. TREATMENT OF EXPANSION / CONTRACTION JOINTS

GREENZONE® EFTS can be installed in expansion joints. GREENZONE® EFTS acts as a physical termite barrier and provides a control for the contraction and expansion of masonry elements.

6.1 TYPICAL USES

GREENZONE® EFTS is suitable for use in these expansion joint applications:

- Non-continuous concrete slabs (Figure 6.1 A)
- Concrete Infill slabs,
- Precast panel to concrete footings junctions and precast panel to paving junctions (Figure 6.1 B),
- Garage with double brick wall on boundary (Figure 6.1 C).
- Post construction application of Paint and/or Backer Rod (Figure 6.1 D).

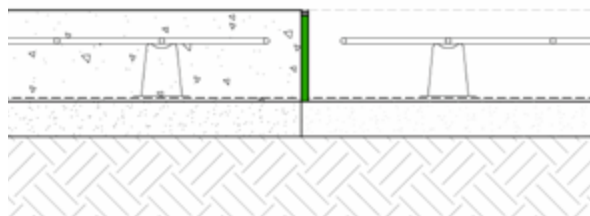

FIGURE 6.1 A

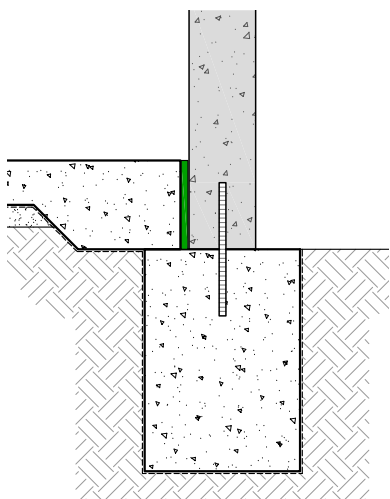

FIGURE 6.1 B

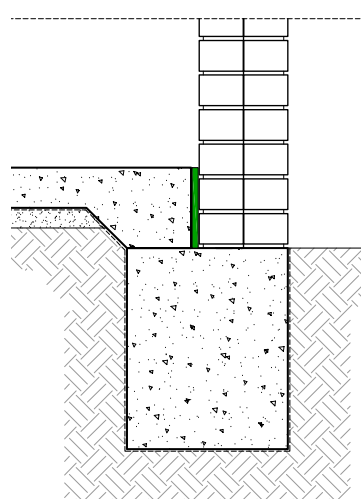

FIGURE 6.1 C

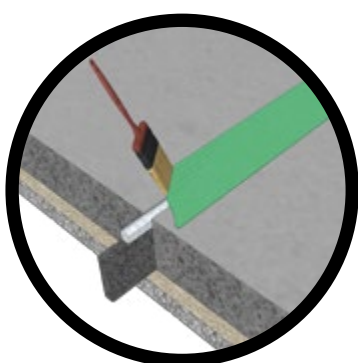

FIGURE 6.1 D

6.2 GENERAL PREPARATION

Before commencing work on site a general site inspection should be undertaken to determine if the site contains any signs of termites. If termites are located on the site, the installer needs to take the necessary steps to remove the termites and their nest prior to commencing work.

Ensure the surface (i.e. surface to which GREENZONE® EFTS will be applied) of the fixed element of the expansion joint is clean and free of dirt, grease, oil and release residues etc.

The installation of GREENZONE® EFTS is made easy due to the sticky back (self-adhesive) backing. This product will stick to most surfaces, e.g. concrete, brick, timber, metal and PVC.

Given the site circumstances the accredited installer may decide to also apply a suitable spray adhesive to enhance the 'sticking' of the product to the vertical slab surface.

6.3 WORK AREA PREPARATION

Ensure edge to concrete slab is clean, free from imperfections, defects, and is flat to ensure an adequate adhesion of GREENZONE® EFTS to the concrete slab edge.

Remove any bumps with the appropriate tool(s) and fill any divots/crevices/voids with an approved termiticide sealant / filler (See section 10.3 for approved sealants) and let dry. Once dry, application of GREENZONE® EFTS can commence.



GREENZONE®

6.4 CONCRETE SLAB

1. Starting from the left-hand end and working towards the right-hand end:
 - a. peel off a small section of the protective coating to the self-adhesive backing,
 - b. working from left to right place the GREENZONE® EFTS on the concrete slab edge, applying sufficient pressure to adhere to the concrete slab ensuring there are no gaps, kinks or air pockets between the GREENZONE® EFTS and the concrete edge,
 - c. at the same time, making sure that the top edge of the GREENZONE® EFTS is flush with the concrete slab – this will allow for consistency when removing the 10mm zip strip prior to sealing of joint,
 - d. moving across from left to right apply the GREENZONE® EFTS to the concrete slab edge – maintaining sufficient pressure to adhere the GREENZONE® EFTS to the concrete slab edge,
 - e. on reaching the required end point - with a sharp knife or scissors, cut the GREENZONE® EFTS to the required length and push into position ensuring no gaps are present,
 - f. if required, seal any small gap with an approved termiticide sealant such as Termiflex,
 - g. **NOTE:** for long continuous joints, where multiple rolls are required, GREENZONE® EFTS must be joined appropriately – (See section 7 for details on joints).

6.5 EXTERNAL PERIMETER EXPANSION JOINT



FIGURE 6.5 A GREENZONE® EFTS used as a barrier between the external perimeter of the building and a ramped path/access way.



FIGURE 6.5 B GREENZONE® EFTS used as a barrier between the building and an external pathway and across doorways/openings into the building.

6.6 CONCRETE PRECAST PANELS / INFILL SLAB / DOUBLE BRICK WALL

1. Starting from the left-hand end and working towards the right-hand end:
 - a. determine the height of the finished concrete slab and mark a line on the concrete tilt panel,
 - b. all recessed panel joints and external corners are required to be filled prior to applying GREENZONE® EFTS – recessed panel joints and external corners are shown in blue in Figures 6.6 A, 6.6 C and 6.6 D,
 - c. peel off a small section of the protective coating to the self-adhesive backing,
 - d. working from left to right, place the GREENZONE® EFTS on the concrete tilt panel to the marked line (finished height of the concrete), applying sufficient pressure to adhere to the surface ensuring there are no gaps, kinks or air pockets between the GREENZONE® EFTS and the concrete panel,
 - e. making sure that the top edge of the GREENZONE® EFTS is flush with the finished concrete slab height – this will allow for consistency when removing the 10mm zip strip prior to applying approved sealant to the joint,
 - f. moving across from left to right apply the GREENZONE® EFTS to the concrete panel surface – maintaining sufficient pressure to adhere the GREENZONE® EFTS to the concrete,
 - g. on reaching the required end point - with a sharp knife or scissors, cut the GREENZONE® EFTS to the required length and push into position ensuring no gaps are present,

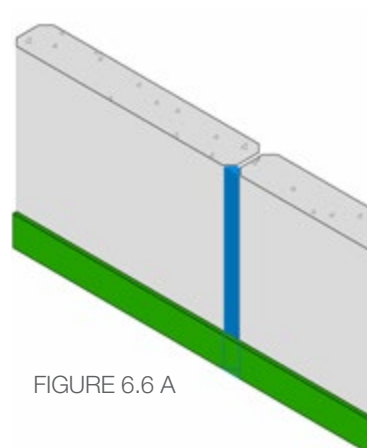

FIGURE 6.6 A

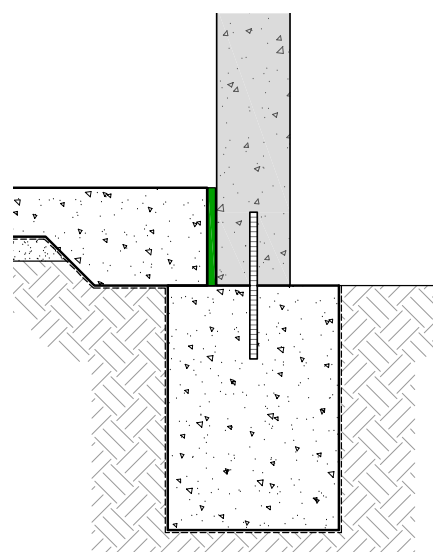

FIGURE 6.6 B

NOTE: for long continuous joints, where multiple rolls are required, GREENZONE® EFTS must be joined appropriately – (See section 7 for details on joins).



FIGURE 6.6 C

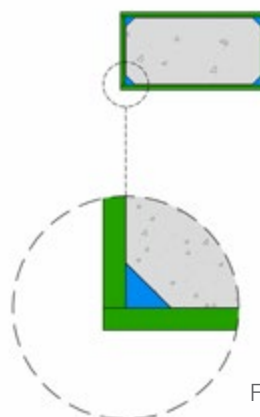

FIGURE 6.6 D



GREENZONE®



FIGURE 6.6 E

6.7 POST CONSTRUCTION APPLICATION OF BACKER ROD AND PAINT

Refer to the detailed installation and application instructions for Backer Rod and Termite Paint.

In summary:

- a) Work along the edge of standard construction joint foam with a stanley knife to remove a section of that foam to a depth of 20-25mm to create space for GREENZONE® Backer Rod to be inserted.
- b) Ensure area is free of debris, standing water, residues or oils prior to installing backer rod x ref surface prep.
- c) Apply Primer or spray adhesive to the area following the relevant instructions and allow to dry
- d) GREENZONE® Backer Rod should be firmly pressed into the recess created by hand or blunt tool which ensures it acts as a bond breaker for the GREENZONE® Termite Paint System
- e) Apply two coats of termite paint system following the relevant instructions.

7. TREATMENT OF GREENZONE® EXPANSION FOAM TERMITE SYSTEM JOINTS AND JOINS

7.1 EXTERNAL AND INTERNAL CORNERS

GREENZONE® EFTS can be applied as a continuous element around internal and external corners provided the slab/footing is in good clean condition and free of debris.

For external corners, GREENZONE® EFTS should be applied in a continuous straight edge up to the corner and GREENZONE® Termite Paint in Cartridge Caulked form must be applied in a beaded pattern stretching 100mm vertically from the base of the corner edge. For gaps larger than 15mm insert GREENZONE® Backer Rod before caulking. Continue to wrap GREENZONE® EFTS around the angled corner to continue the straight edge past the corner.

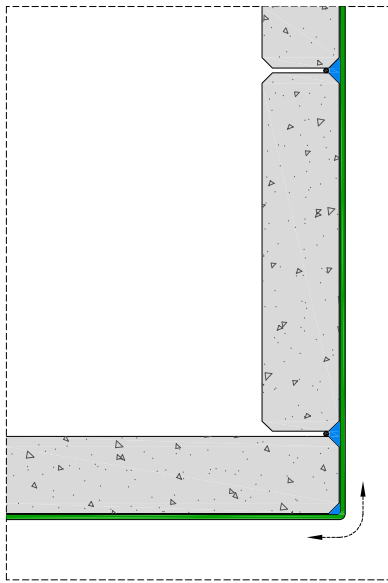

FIGURE 7.1 A

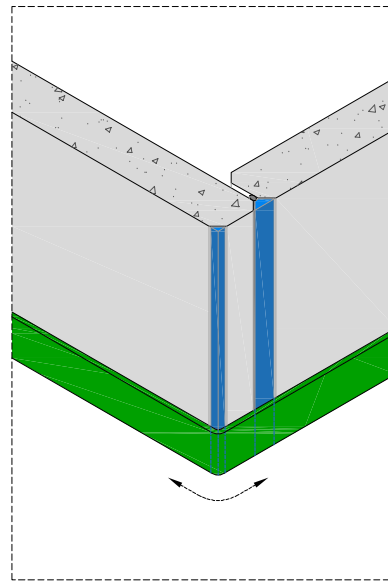

FIGURE 7.1 B

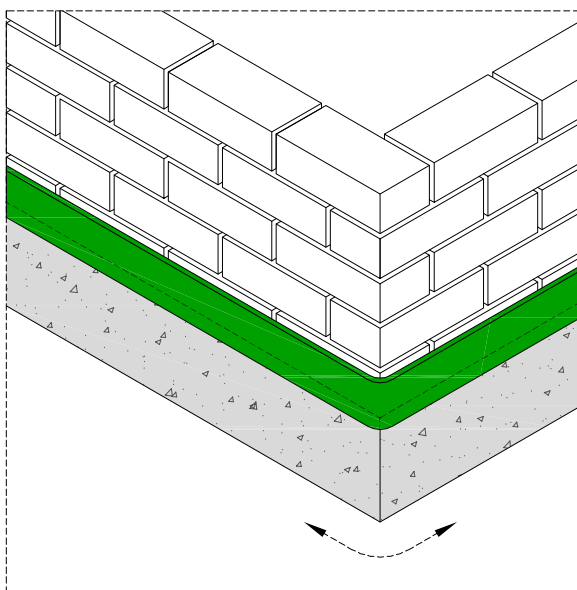

FIGURE 7.1 C

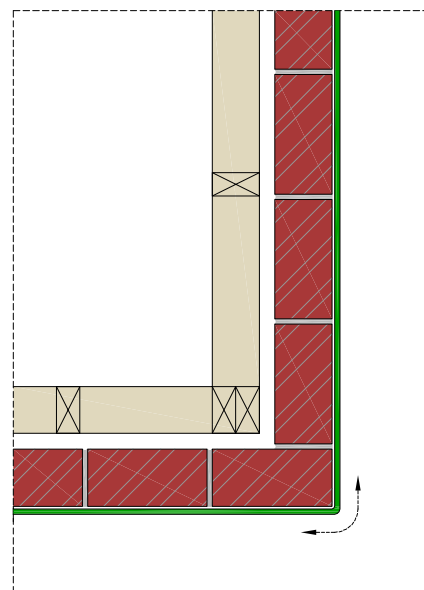

FIGURE 7.1 D



For internal corners, GREENZONE® EFTS should be applied in a continuous straight edge up to the corner and GREENZONE® Termite Paint must be applied in a beaded pattern stretching 100mm vertically from the base of the corner. Where there may be a gap or void greater than 15mm insert backer rod before caulking. GREENZONE® EFTS should then be folded into the corner and continue the straight edge past the corner.

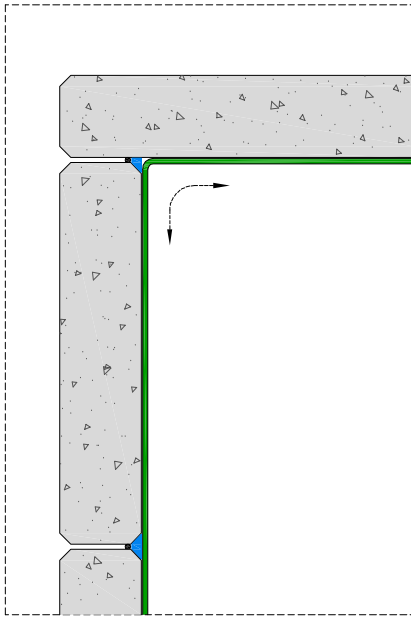

FIGURE 7.1 E

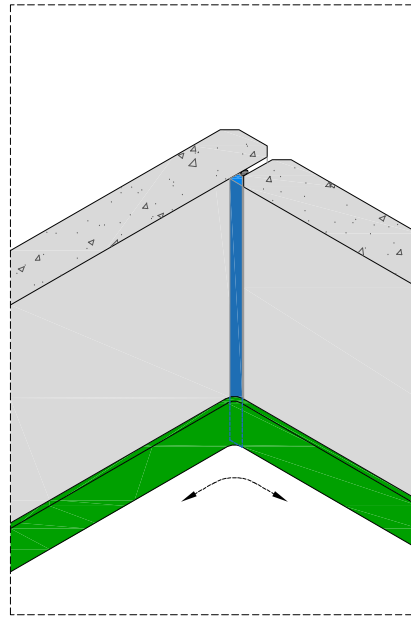

FIGURE 7.1 F

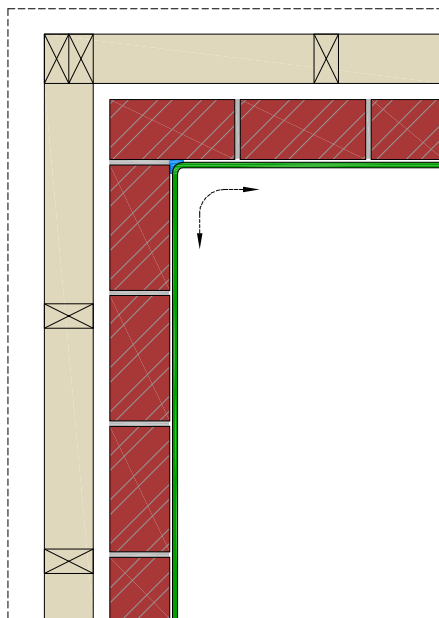

FIGURE 7.1 G

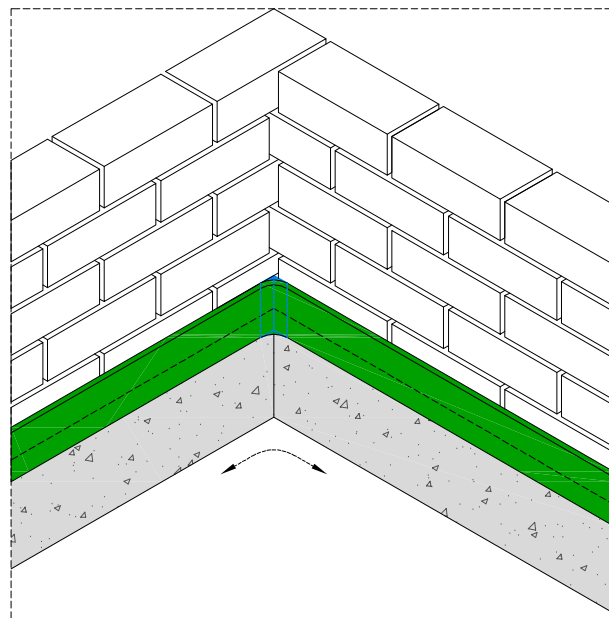

FIGURE 7.1 H

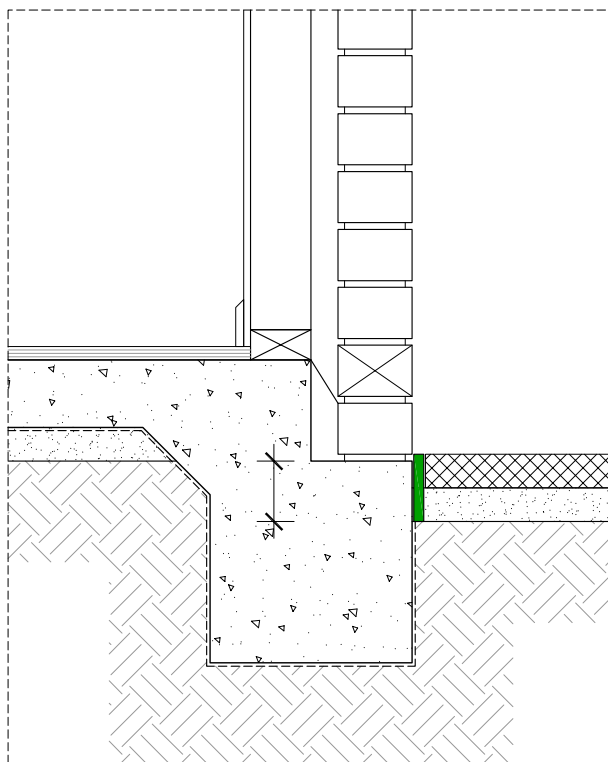

FIGURE 7.1 I GREENZONE® Expansion Foam Termite System being used between external walls and pathways

7.2 END-TO-END JOINTS (BUTT JOINS)

Simply cut GREENZONE® EFTS, with a sharp knife or scissors, to form a straight edge which is cut at 90 degrees to the face – then attach one piece of the GREENZONE® EFTS to the applicable surface and then place the next piece of GREENZONE® in tightly with the piece secured to the surface. Fill any gaps with appropriate sealant.

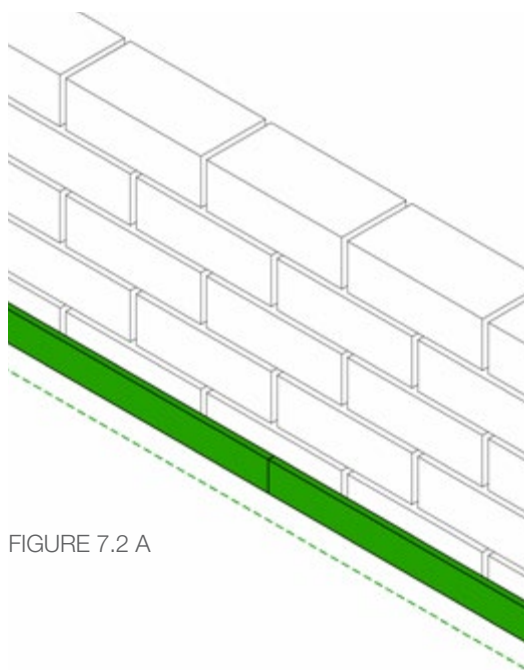

FIGURE 7.2 A

GREENZONE® SOCK TERMITE SYSTEM



8. SERVICE PENETRATIONS

GREENZONE® Sock Termite System (STS) can be installed around service penetrations in masonry structures, e.g. concrete slabs, concrete walls, block and brick walls. GREENZONE® STS acts as a physical termite and insect barrier and provides a compressible foam joint for the contraction and expansion of masonry elements.

8.1 TYPICAL USES

GREENZONE® STS is suitable for use generally in these areas:

- Around Plumbing Pipes – Drains (nominal 25, 40, 50, 80 and 100mm diameter PVC pipes)

8.2 GENERAL PREPARATION

Before commencing work on site, a general site inspection should be undertaken to determine if the site contains any signs of termites. If termites are located on the site, the installer needs to take the necessary steps to remove the termites and their nest prior to commencing work.

8.3 INSTALLATION AROUND SINGLE SERVICE PENETRATIONS IN A TYPICAL CONCRETE SLAB

The GREENZONE® STS can be installed at any time prior to the concrete being poured. This includes application of the Sock before and after the concreter has setup the formwork. Greenzone recommends that the GREENZONE® STS be installed no more than two weeks before concrete is poured.

There are two options when fitting the sock to the penetration, 1) Simple Slide-on and 2) Slide-on and Fold. The installation method for the two options is as follows.

8.4 INSTALLATION METHOD FOR THE SIMPLE SLIDE-ON OPTION

STEP ONE

1. Clean pipe with appropriate tool(s) to ensure that the pipe is smooth, is free of dirt, concrete, adhesives, grease, oil and the like, is dry and is free of any other defect (e.g. split, break, puncture or divot). Ensure that the top of the pipe is free from sharp / rough edges, cracks, splits which may cause the GREENZONE® STS to be compromised whilst being installed (e.g. the sock is torn or damaged).
2. Establish approximate height of finished concrete and the thickness of the concrete slab (A):
 - a. Mark on the service penetration the finished concrete slab height (B),
 - b. Mark on the service penetration the underside position of the concrete slab (C).
3. When applying GREENZONE Sock Termite System, ensure the Sock is centred over (B) and (C).

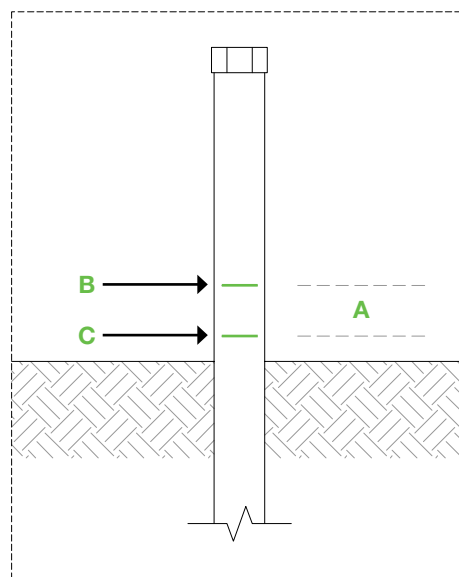

FIGURE 8.4 A

STEP TWO

1. Select the correct size of GREENZONE® STS required:
 - a. remove any rough edges from the pipe, and if fitted, check pipe caps for sharp or rough edges – remove as required.
 - b. slowly slide the GREENZONE® STS over the pipe penetration until the sock is in the correct position.
 - c. as the GREENZONE® STS is applied to the pipe ensure that there are no kinks, rips, tears or defects in the material – (if any of these are found in the material please refer to section 10.4 on repairs etc.)
2. Once installed apply the warning tape to the top of the penetration. Warning tape is supplied as a separate item – See 10.1 for details.

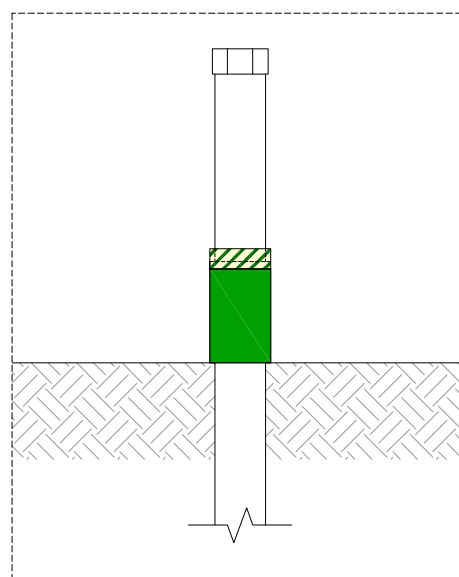

FIGURE 8.4 B



GREENZONE®

**IMPORTANT NOTES
TO CONCRETER**

- The placement of any reinforcement mesh and bar chairs shall not be closer than 50mm to the GREENZONE® STS. (See Figure 8.4 C)
- If applicable, the plastic membrane shall be neatly cut around the service penetration and secured over the GREENZONE® STS with appropriate tape. The plastic membrane and tape shall be positioned a minimum of 50mm from the finished height of the concrete slab. (See Figure 8.4 C)

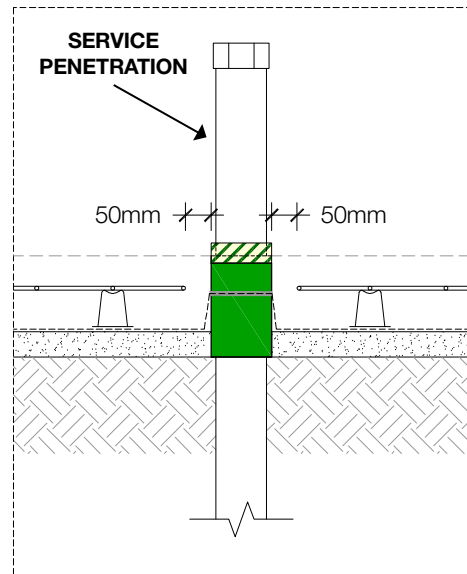

FIGURE 8.4 C

On completion of concreting

1. Once the concrete has been poured and cured, any excess of the GREENZONE® STS around the service penetration should be removed.
2. To remove, using a sharp knife, cut the GREENZONE® STS around the penetration at the height of the finished floor level. (See Figure 8.4 D).
3. Any gaps, voids, holes between the service penetration and GREENZONE® STS shall be filled with suitable termiticide sealant, e.g. Termiflex.

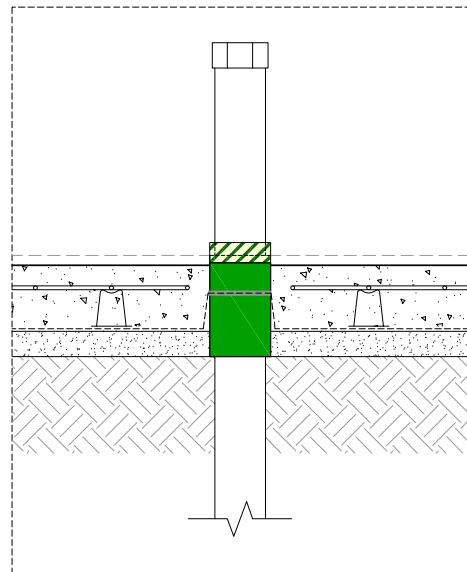

FIGURE 8.4 D

8.5 INSTALLATION METHOD FOR FOLD OVER OPTION

Installation in accordance with Australian Standard 3660.1,2014. 5.3.6 – concrete slab penetrations (see Figure 8.5 C (pre pour)).

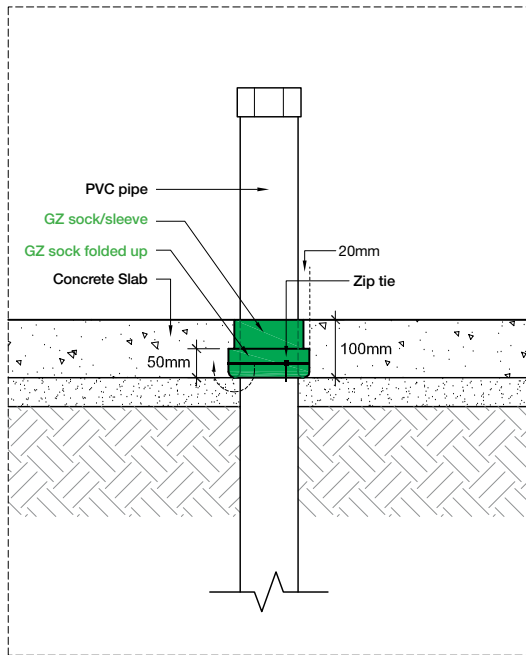

FIGURE 8.5 A

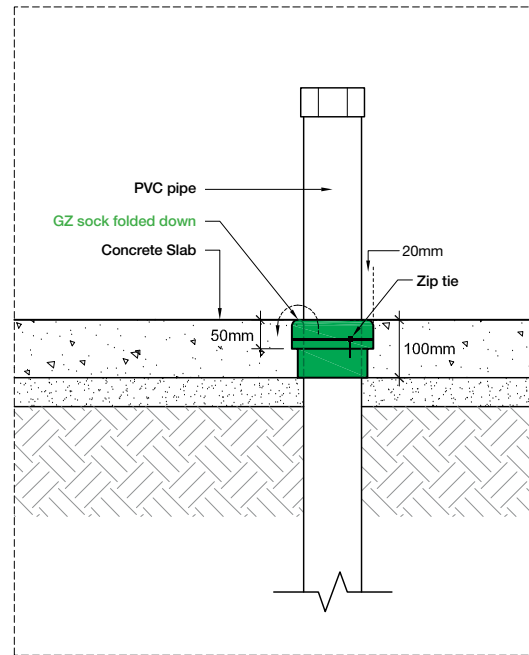

FIGURE 8.5 B



FIGURE 8.5 C

8.6 GREENZONE INSTALLATION TO CONDUITS – PRIOR TO POUR

GREENZONE® Expansion Foam Termite System is cut in approximately 200mm x 30mm strips and wrapped as shown with a 20mm overlap which provides the minimum 15mm product to be cast horizontally into the slab as per AS 3660.1,2014.5.3.6 – concrete slab penetrations (see Figure 8.6 B (pre-pour)).



FIGURE 8.6 A
GREENZONE® EFTS wrapped to conduits.



FIGURE 8.6 B
GREENZONE® EFTS wrapped to a cluster of 2 conduits.



FIGURE 8.6 C
GREENZONE® STS applied to 3 orange conduits; GREENZONE® EFTS applied to 1 conduit. Note - 2 grey conduits not treated as they are cast into the slab.



FIGURE 8.6 D
GREENZONE® EFTS wrapped 2 conduits; GREENZONE® STS applied to 100mm plumbing pipe; GREENZONE® EFTS to cold joint installation. Dowels inserted through the product.

GREENZONE® PERIMETER TERMITE SYSTEM



9. GREENZONE® PERIMETER TERMITE SYSTEM

GREENZONE® Perimeter Termite System (PTS) is a physical termite risk management measure that is flexible in nature and is classified in Australian Standards 3660.1:2014 Section 5 Requirements - Sheet Materials. It is a once only treatment that is designed to last the economical life of the building.

GREENZONE® PTS is installed to areas of the building where termites may ingress. The GREENZONE® PTS is designed to force out the undetected entry of termites where their earthen tunnels and galleries are readily detected.

The onus is on the owner to be vigilant in maintaining a clear 75mm visual inspection zone (see maintenance and guidelines in section 11) in conjunction with regular competent inspections from a qualified GREENZONE® accredited inspector not exceeding 12 months to comply with warranty terms and conditions.

This GREENZONE® training manual provides installation measures to deter termite ingress arising from concealed entry points into the building. The system also relies on a combination of partial measures combined with maintaining perimeter inspection zones so that the evidence of termite workings is forced out into the open where their presence may be detected more readily.

The GREENZONE® PTS works in conjunction with the concrete slab being poured to AS 2870.2011 (or) AS 3600:2018 which form an integral part of the termite risk management measure by using the concrete slab as a physical barrier complying with AS 3660.1-2014 Section 4.4.

9.1 TYPICAL USES

The GREENZONE® PTS can be used in many different instances in the construction of buildings in Australia. Predominately, GREENZONE® PTS is used as a part of the termite management system integrated in the construction of new dwellings.



FIGURE 9.0

9.2 GENERAL PREPARATION

Before commencing work on site, a general site inspection should be undertaken to determine if the site contains any signs of termites.

If termites are located on the site, the installer needs to take the necessary steps to remove the termites and their nest prior to commencing work.

9.3 GENERAL INSTALLATION OF GREENZONE® PERIMETER TERMITE SYSTEM

The GREENZONE® PTS can be installed at anytime after the concrete slab has been poured, but prior to the erection of the internal wall frames. When pinning the management film this should be done at 300mm intervals.

GREENZONE® recommends chalk lines indicating positioning of timber frames are flicked prior to installation of GREENZONE® PTS and recommend installation no more than four weeks prior to installation of external walls.

Alternatively, the GREENZONE® PTS may be installed with a continuous application or bead of suitable construction adhesive. See also Section 9.5 regarding appropriate overlap and method of securing areas of overlap for joins, repairs, and corners.

Where the slab edge includes step downs or rebates for window or door frame or other openings (eg: sliding doors), the GREENZONE® PTS should be continuously applied in these areas with reference to instructions for managing corners to ensure there is no tension or tenting of the GREENZONE® PTS at these interchanges.

9.4 TYPICAL INSTALLATION DETAILS – GREENZONE® PERIMETER TERMITE SYSTEM

The following provides typical (summary) of installation details for the GREENZONE® PTS. GREENZONE® PTS can be used in many different applications. A range of options is provided so that barriers may be used either singularly, or in combination to provide an integrated termite management system.

The following drawings, details and instructions when read in conjunction with the relevant Codes and Standards will provide a comprehensive guide to the correct installation and maintenance of the GREENZONE® PTS.

For further details or to discuss an application that is not detailed below please contact your GREENZONE® Accredited Installer.

GREENZONE® Perimeter Termite System installed to the perimeter of the building.

TYPICAL APPLICATION 1: Concrete Slab with Brick Veneer Construction (Two brick rebate)

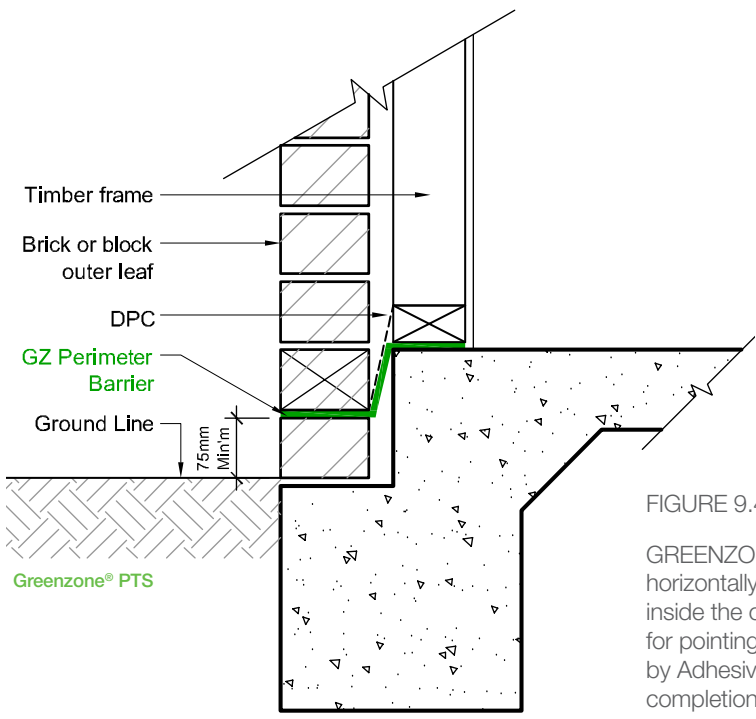
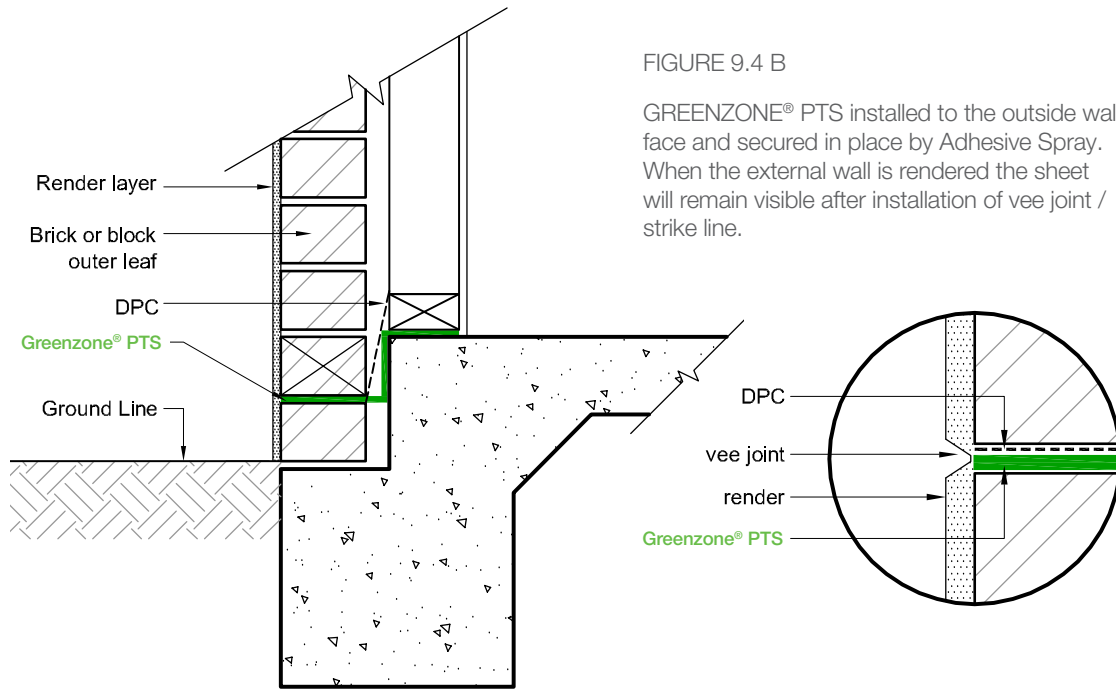

FIGURE 9.4 A
GREENZONE® PTS installed and secured horizontally under timber framing. Install to just inside the outside face of the first brick to allow for pointing of brickwork and secured in place by Adhesive Spray. Product to remain visible on completion of the finished wall.



TYPICAL APPLICATION 2: Concrete Slab with Brick Veneer Construction (Rendered Finish to Brickwork)



TYPICAL APPLICATION 3: Raft slab

Product to remain visible on completion of the finished wall.

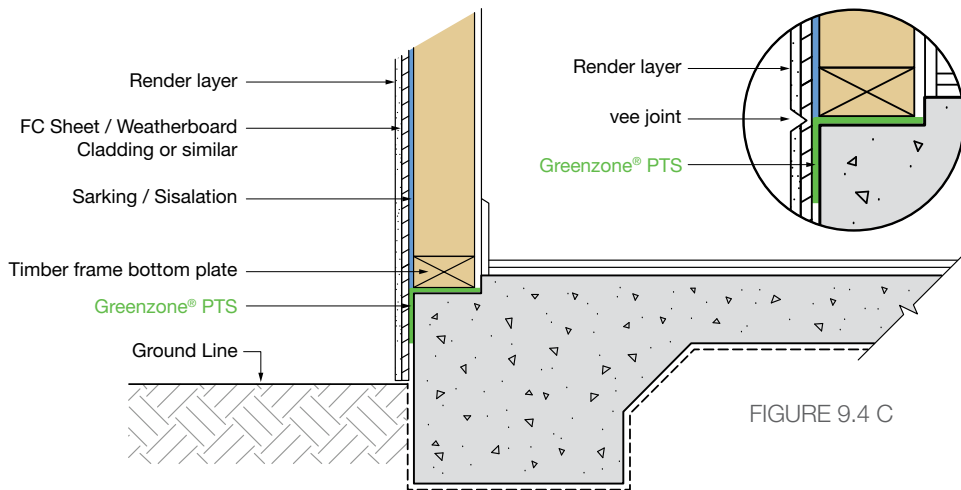

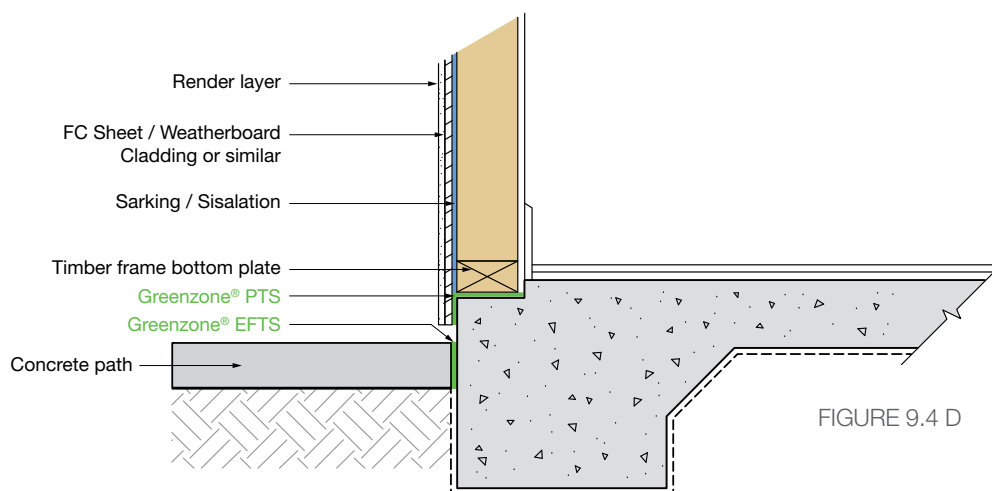

NOTE: GREENZONE® PTS installed under timber frame and extend vertically to the finished height of the cladding. Vee joint / strike line may be optional. For inspection zone requirements install GREENZONE® EFTS as a cold joint installation as shown.

Encroachment of Inspection Zones

There are some 'in situ' situations where inspection zones do not comply upon completion of installations. GREENZONE® has details to address this for both pre and post termite treatments; contact your local GREENZONE® Accredited Installer.

9.5 GREENZONE® PERIMETER TERMITE SYSTEM – JOINS AND REPAIRS

When joining the GREENZONE® PTS strips, a minimum 200mm overlap is required at all perimeter joins, 100mm overlap at all internal and external corners and 150mm overlap in each direction where a repair patch is required.

All GREENZONE® PTS overlaps and repairs are to be glued into position with **3M Scotch-Weld Non-Flammable Foam Fast 74 NF Spray Adhesive** or equivalent.

9.6 TERMITE PROTECTION TO CONCRETE SLAB JOINTS

Not all slab joints require dowels to be inserted. This will be specified on Architectural / Engineer plan section details.

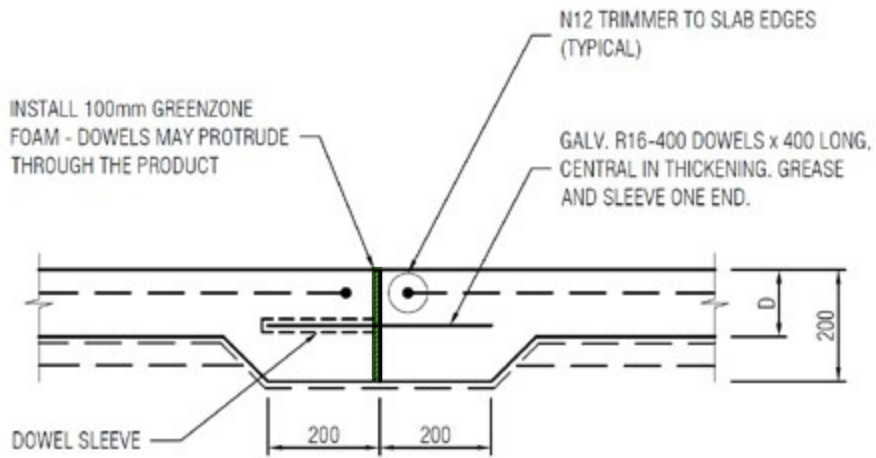

FIGURE 9.6 A Dowelled Expansion Joint (DEJ) typical detail

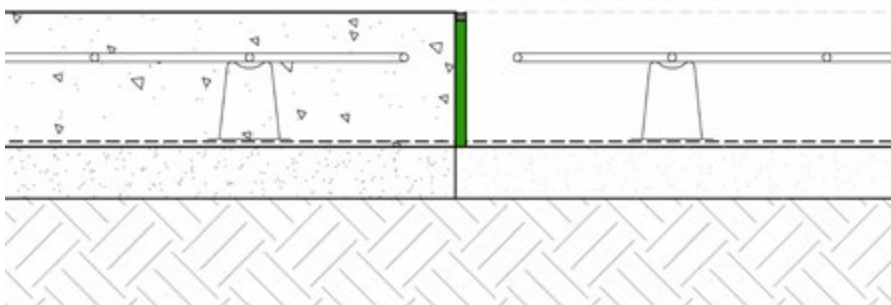

FIGURE 9.6 B Not all slab joints require dowels to be inserted. This will be specified on Architectural / Engineer plan.



FIGURE 9.6 C Examples of dowels inserted to cold joint installation of GREENZONE® EFTS.

9.7 TERMITE PROTECTION TO SAW CUTS

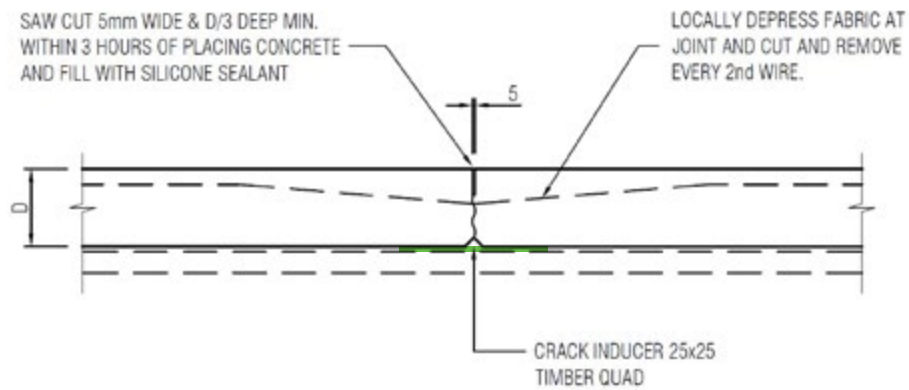

FIGURE 9.7 A Saw Cut Joint (SCJ) typical detail

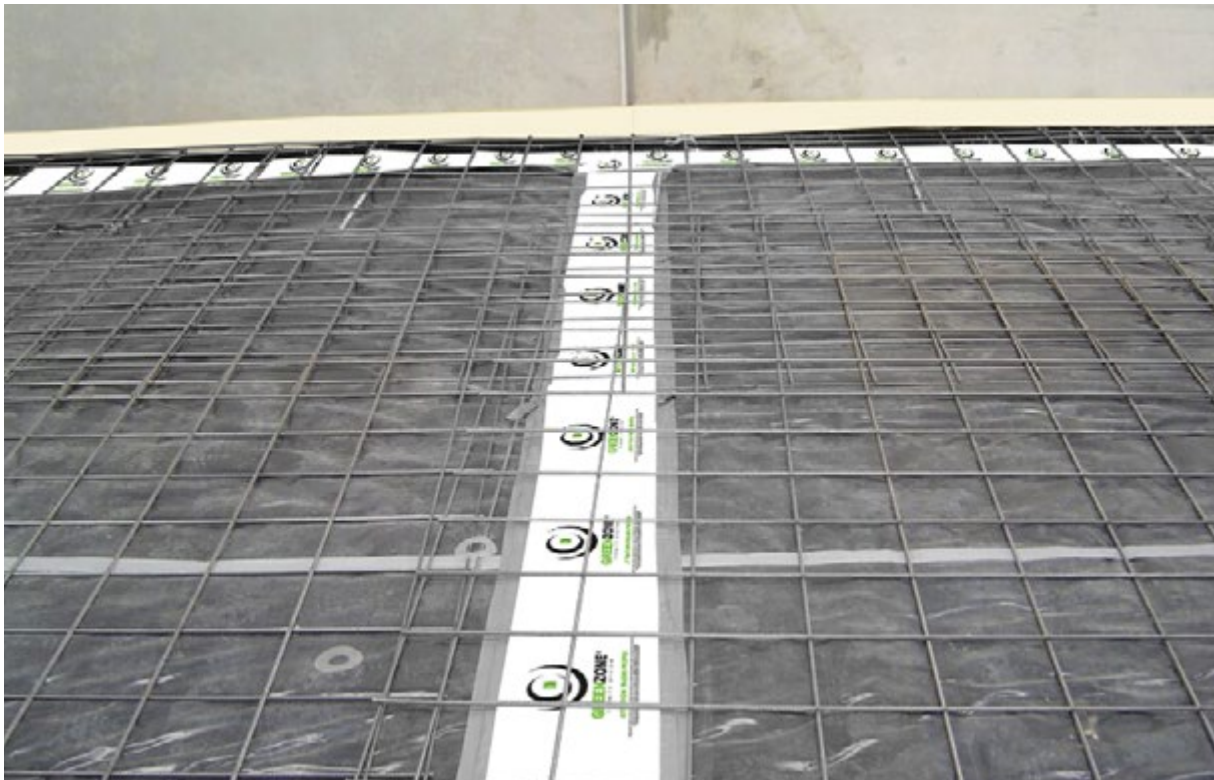

FIGURE 9.7 B GREENZONE® Perimeter Termite System (PTS) (300mm wide) is installed – taped horizontally to the moisture membrane.
This is a concrete tilt up – the product is to overlap the internal perimeter protection.
The detail for brick – veneer the product is installed onto the external brick work to overlap the GREENZONE® PTS installation.

9.8 GREENZONE® PERIMETER TERMITE SYSTEM – EXTERNAL CORNER DETAIL

The GREENZONE® PTS is to be installed on external corners as shown below. Care is to be taken when cutting and folding the sheet to ensure adequate adhesion to the substrate (i.e. brickwork).

Note: the following details are based on a two-brick rebate in the concrete slab. For a one brick rebate the GREENZONE® PTS would simply be laid over itself on the external corner – forming a 300mm x 300mm overlap.

STEP 1 & 2

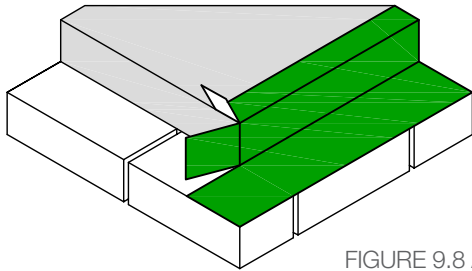

FIGURE 9.8 A

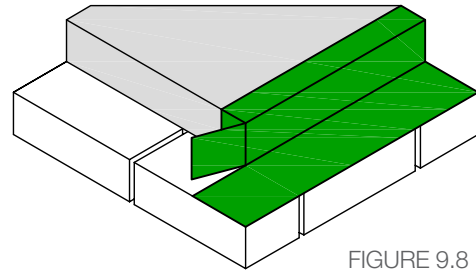

FIGURE 9.8 B

STEP 3 & 4

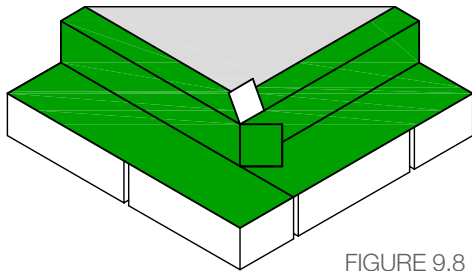

FIGURE 9.8 C

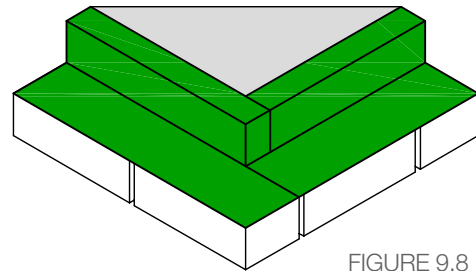

FIGURE 9.8 D

9.9 GREENZONE® PERIMETER TERMITE SYSTEM – INTERNAL CORNER DETAIL

The GREENZONE® PTS is to be installed on internal corners as shown below. Care is to be taken when cutting and folding the sheet to ensure adequate adhesion to the substrate (i.e. brickwork).

Note: the following details are based on a two-brick rebate in the concrete slab. For a one brick rebate the GREENZONE® PTS would simply be laid over itself on the internal corner – forming a 300mm x 300mm overlap.

STEP 1 & 2

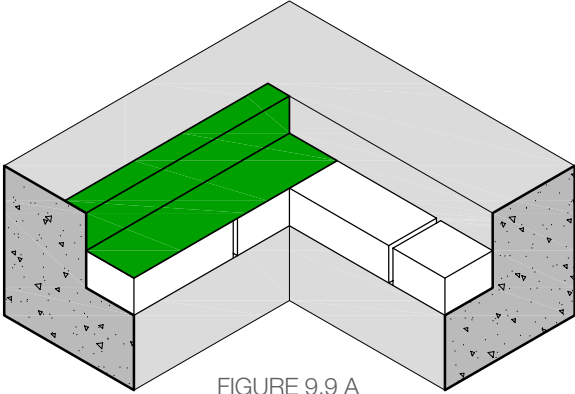

FIGURE 9.9 A

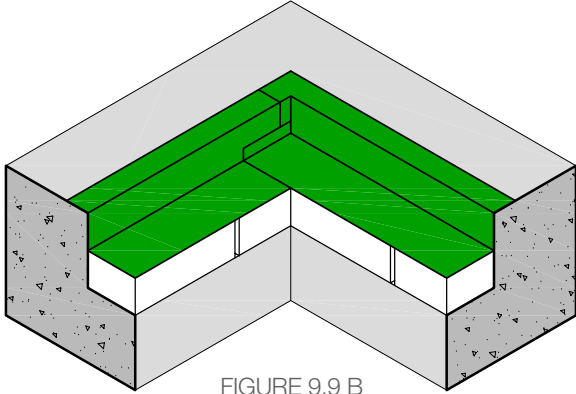

FIGURE 9.9 B



FIGURE 9.9 C



9.10 GREENZONE® EXTERNAL PERIMETER CORNERS

The GREENZONE® External Perimeter Corner can be installed directly on to cement corner with glue and pins and then perimeter sheet secured over the top of the external corner (Figure 9.10 A), or

Perimeter sheet secured along the cement edge and GREENZONE® External Perimeter Corner glued and pinned over the top of perimeter sheet (Figure 9.10 B).



FIGURE 9.10 A



FIGURE 9.10 B

9.11 GREENZONE® INTERNAL PERIMETER CORNERS

The GREENZONE® Internal Perimeter Corner can be installed directly on to cement corner with glue and pins and then perimeter sheet secured over the top of the internal corner (Figure 9.11 A), or

Perimeter sheet secured along the cement edge and GREENZONE® Internal Perimeter Corner glued and pinned over the top of perimeter sheet (Figure 9.11 B).



FIGURE 9.11 A



FIGURE 9.11 B

GREENZONE® TERMITE PAINT SYSTEM



10. GREENZONE® TERMITE PAINT SYSTEM

GREENZONE® Paint is a chemical termite risk management product that is designed to create a continuous barrier.

It is classified in AS 3660.1, 2014 as a Chemical Barrier. It is particularly useful in circumstances where a preconstruction termite system such as GREENZONE® PTS or Expansion Joint Foam was inadvertently not applied prior to concrete being poured. It is also useful in augmenting the installation and application of the other GREENZONE® products and to correct instances of damage to the termite system post concrete pour.

GREENZONE® Paint is applied to areas of the building where termites may ingress. The GREENZONE® Paint is designed to force out the undetected entry of termites where their earthen tunnels and galleries are readily detected.

10.1 TYPICAL USES

The GREENZONE® Paint can be used in many different instances in the construction of buildings in Australia. Predominately, GREENZONE® Paint is used as a part of the termite management system integrated in the construction of new dwellings and to undertake remedial works in situations of renovation and when a preconstruction termite system has been inadvertently omitted.

With correct surface preparation it may be applied to

- concrete, including concrete blocks and aerated concrete
- masonry
- renders and screeds
- uPVC (Must be Primed and roughing of surface is recommended)
- galvanized iron and zincalume metal surfaces
- clay bricks and pavers
- Cement sheeting, plasterboard and wet area linings (please note that the use of Greenzone may interfere with other product manufacturers warranties specifically as it relates to plasterboard products.)



FIGURE 10.0

10.2 SITE & SURFACE PREPARATION

The installer should consider and assess the following factors specific to the site and construction materials the paint is being applied to including but not limited to:

10.1.1 Damp and Hydrostatic Pressure

Specifically, the surface of construction materials should be inspected to identify if the areas are affected by moisture – specifically instances of rising and other forms of ‘damp’ or hydrostatic pressure (where moisture may enter via the other side of the untreated wall, where waterproofing has not been applied). GREENZONE® Paint will bubble and degrade when applied to surfaces affected by moisture in this manner.

Generally, the area can be moist but no surface or standing water (or rising damp or evidence other hydrostatic pressure) should be present.

10.1.2 Scheduling & Consultation

Consultation with Site Management should be undertaken prior to application to ensure consideration and where required relevant action is taken to address the following:

- Expected and current weather conditions, the substrate surface should be free from standing water or rain for approx. 24hrs so that it dry immediately prior to and post application.
- That the concrete and or masonry to which GREENZONE® Paint is to be applied has completed its own required curing time and any area to be treated within the curated time has a remaining unpainted area within 500mm to allow for continued curing of the concrete slab. Any entire concrete slab areas to be treated should be fully cured prior to application.
- That other coatings such as Waterproofing are applied after GREENZONE® Paint and that the proposed Waterproofing doesn't contain Solvents. The exceptions to this are when Cementitious Sealants are being used as waterproofing, GREENZONE® Paint should be applied AFTER this.

- That further works scheduling will ensure that GREENZONE® Paint has sufficient time to cure before it may be interacted with (see curing times). If works scheduling requires site access or other activity that may result in uncured GREENZONE® Paint being affected, consider protective coverings or barrier tape to deter access to that specific area. It is recommended the site supervisor review to ensure no further damage to the continuous barrier. Reinstatement may be required.
- If capping or painting for colour matching and traffic protection is to be applied ensure the Site Supervisor has checked that the proposed products are suited for use and sufficient product curing time occurs before they are applied.

10.1.3 Surface Preparation

The area for application may require manual clearing and cleaning, blowing scraping or brushing or possibly even high pressure washing with water or even hydrochloric acid prior to application of either the Primer and / or Paint.

The aim of this is to ensure proper adhesion and prevent bubbling, lifting or degrading of the termite barrier. All areas to be treated should be brushed, cleaned, gap filled and made smooth prior to commencement.

10.1.4 Primer Application

- Apply primer to all horizontal and vertical surfaces to be treated with GREENZONE® Paint. Apply using a soft paint brush or roller to ensure all porous areas are covered sufficiently. A soft bristle broom works well for application to larger areas.
- Commercially available adhesive sprays may be used in lieu of primer for small area application.
- Primer rate of application is: 160ml / m² (this may vary depending on how porous the surface is). You should expect to be able to prime between 6-8m² per 1Litre of Primer.
- Primer will dry usually within 10-15 minutes at an average of a 20degree Celsius day. This may vary depending on weather condition and how porous the substrate surface is. It will appear clear when dried.
- Primer may be cleaned with water whilst still damp or thinners may be required if product has been left to dry on applicators.
- GREENZONE® Paint should be applied within 24 hours of application of primer as the primer is not stable when exposed
- Remediate any primed surface areas that become dirty and dusty with a damp cloth
- It is recommended to complete priming of all areas to be treated before starting the application of GREENZONE® Paint.

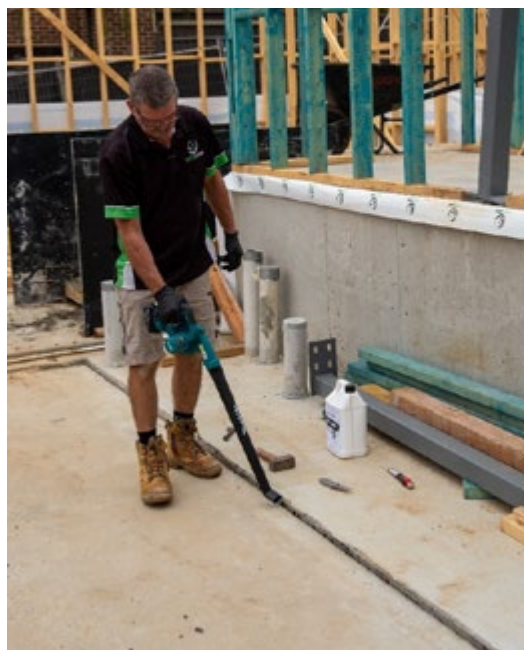

10.2 GENERAL APPLICATION OF GREENZONE® PAINT

The GREENZONE® Paint can be applied at any time after the primer has cured and within 24 hours of primer application.

There are two primary methods of application for GREENZONE® Paint, as a caulking bead and as a sealant. The difference between these two application methods is that any application wider than 15mm is considered a sealant application and less than 15mm is considered a bead application.

10.2.1 Caulking Bead Application

Application as a caulked bead of at least 5mm width and 10mm depth must be no more than 15mm wide otherwise sealant application directions apply. Generally, the caulking bead application width must be not less than half of its depth. Depth must not be more than twice the width.

Once cured, the caulking bead has a maximum range of movement of approximately +/- 50% at joints and pipes. In construction situations where significant joint or other movement is expected and or the gap to be filled is greater than 15mm use Backer Rod and or Self-Adhesive Fibre Glass Tape in conjunction.

Consider the proposed use of caps and colour matching paints or other sealants or mastic. The finished level should allow for the installation or application of subsequent products.



Insert sausage into cartridge and then push tip into areas where bead is to be applied ensuring consistent application, adhering to dimensions documented above, without breaks, gaps or bubbles to ensure a continuous barrier.

Ensure all areas are filled and press down with a spatula where needed.

10.2.3 Sealant Application Method

It is recommended that the Sealant method be applied in all situations where there is an area greater than 15mm width to be treated.

Dimensions of Sealant Application should be:

- a minimum thickness of 2.5mm per coating noting that some thickness will be lost on curing due to evaporation.
- 50mm either side of edge of the construction join
- on vertical applications a minimum of 150mm height should be applied.

The product may be applied from a bucket. Stir until texture is even and smooth. Repeat during application as needed and ensure paint bucket is kept within appropriate temperature range.

Apply using a brush, roller or spray, ensuring consistent application and specified dimensions are maintained.



Coverage should be complete and regular but need not be smooth in presentation. Ensure there is no bubbling, breaks or uneven distribution of product. Two coats must be applied provided there is effective curing time in between coats.

10.2.4 Clean Up

Keep a cloth and clean water handy during application as removal and clean up immediately of wet product (either Primer or Paint) is best achieved with water.



10.2.5 Protection of Treated Areas

In most construction situations treated areas will be covered with floor and wall coverings.

However, where Greenzone paint is applied on surfaces that will experience traffic and abrasion or be exposed to UltraViolet (UV) sunlight or potentially materials like solvents (petroleum-based products, powerful detergents or any product that is highly alkaline or acidic) the area should be protected with two coats of acrylic paint, a suitable capping or floor covering.

This is likely to affect horizontally treated areas rather than vertical caulked bead joints. However, the top and bottom of vertical beads may be more exposed to sunlight, traffic and solvents in which case the following guidance applies.

All subsequent treatments should be applied after curing is achieved.

Ensure all products to be used are water based. DO NOT use:

- Oil or solvent based paint
- Two pack urethanes
- Silicone
- Abrasion resistant floor coatings
- Paving paint

If you are uncertain about whether a sealant or paint or render contains these products confirm with Greenzone prior to use.

Apply in conjunction with water-based primers as directed by manufacturer. The paints and renders can also be used for colour matching purposes.

Any materials used to prevent interaction with traffic and abrasion should not damage the bead or sealant and should be protected from solvents and installed correctly.

Sealants, paints, and coverings should be used in conjunction with each other when it is likely that multiple risk factors UV, traffic and solvents may affect the termite barrier.



GREENZONE® BACKER ROD



11. GREENZONE® BACKER ROD SYSTEM

GREENZONE® Backer Rod is used to seal voids. It is an extruded polymer foam that contains an insecticide (specifically Bifenthrin). As such it acts as both a chemical and physical deterrent and barrier to prevent general pest ingress through building openings like the gaps around windows and doors. It is applied during construction.

11.1 TYPICAL USES

In addition to prior uses described, Backer Rod can also be used to prevent pest ingress via building openings. In this context it is a stand alone product not to be used with paint for the purpose of contributing to a complete pest management prevention system, specifically targeting Cockroaches, Ants and other pests like spiders, fleas and silverfish.

Some example installation applications include:

- Windows
- Doors
- Horizontal Service Penetrations
- Skylights



11.2 SITE & SURFACE PREPARATION

Prior to installing GREENZONE® Backer Rod as a general pest barrier around a building opening you should ensure the area is free of dirt, debris, oils, solvents or other contamination.

11.3 GENERAL INSTALLATION OF GREENZONE® BACKER ROD

The GREENZONE® Backer Rod can be pushed into openings and gaps around windows and doors by hand or blunt tool and the aim is to create a continuous barrier.

Tape or a commercially available adhesive spray can be used to fix down ends that should abut.

Ensure a sufficient recess is allowed where it is to be covered with sealant or mastics.

Any sealant or mastic used after installation should not be water based (not solvent).



12. GREENZONE® ACCESSORIES

12.1 WARNING TAPE (REMOVABLE COVER FROM SELF-ADHESIVE STRIP)

The paper cover removed from the self-adhesive strip is to be wrapped around the top section of the penetration (i.e. above where the GREENZONE® product finishes) using a clear masking tape to adhere it to the penetration. (See Figure 10.1B) This is used to warn other trades people on site that GREENZONE® has been installed as a termite barrier. Accordingly, it should not be tampered with, damaged or removed.

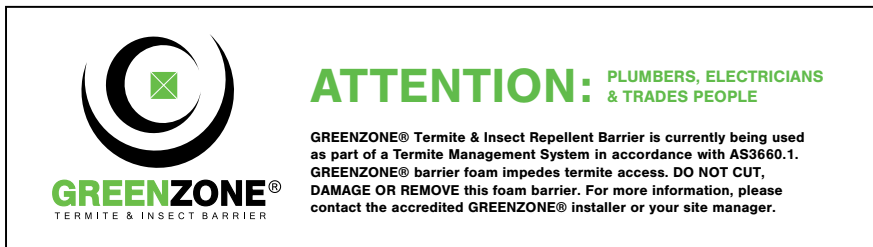

FIGURE 10.1 A

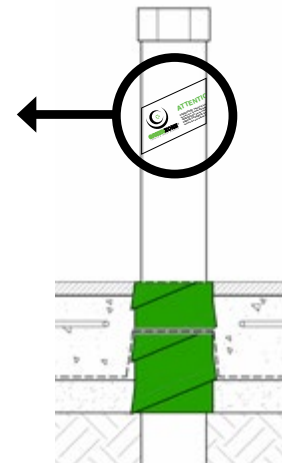

FIGURE 10.1 B

12.2 WARNING TAPE (SELF ADHESIVE)

A self-adhesive warning label tape is available, purchased separately, in roll form (48mm wide x 66m long). This tape is to be applied around the penetration on which the GREENZONE® Sock Termite System product has been used. Also, it can be used where the GREENZONE® Expansion Foam Termite System product has been applied to a penetration.



FIGURE 10.2 A



FIGURE 10.2 B

13. GREENZONE® MAINTENANCE & REPAIRS

13.1 REPAIRS AND PATCHING

Should the GREENZONE® Expansion Foam Termite System be damaged during or post installation, the following outlines the steps required to repair the affected area:

1. Cut out the affected area with a sharp knife, making sure that the cuts are straight and square.
2. Measure and cut a fresh piece of the GREENZONE® EFTS.
3. Before inserting the new piece of GREENZONE® EFTS place a bead of sealant on each end of the cut out.
4. Peel off the sticky back adhesive backing paper.
5. Place the new piece as required and apply sufficient pressure to ensure adhesion to the substrate.
6. Ensure any gaps, void or divots are filled fully with appropriate sealant.



FIGURE 13.1 A



FIGURE 13.1 B

14. GREENZONE® MAINTENANCE, WARRANTY & REGISTRATION

The GREENZONE® warranty terms and conditions (see section 12) require that annual inspections must be undertaken by a licenced and accredited GREENZONE® installer.

The onus is on the owner to be vigilant in maintaining a clear 75mm visual inspection zone in conjunction with regular competent inspections from a qualified GREENZONE® accredited inspector not exceeding 12 months to comply with warranty terms and conditions.

Where no visible inspection zone is possible it is to be recommended to the builder that ideally access and inspection hatches be installed to allow future inspection where possible.

Where this is not possible the lack of suitable inspection zones should be noted on the Certificate of Installation and the Inspector should ensure use of additional thermal imaging inspections during annual warranty inspections.

For further details contact the GREENZONE® Accredited Pest Control Operator whom installed the termite management system or contact Green Zone Pty Ltd for a list of approved accredited pest control operators in your area – see **www.greenzonebarrier.com**

14.1 WARRANTY & REGISTRATION

GREENZONE® products come with a warranty, for full details of the warranty and to register your project go to: **www.greenzonebarrier.com**

From the Greenzone homepage, click on the 'Resources' menu and go to 'Members Login' which will take you to the Members Dashboard. From here, click on 'New Registration and Compliance Documents' and go through the process of filling in the registration and compliance document.

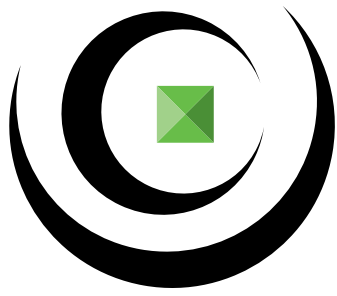

GREENZONE®
TERMITE & INSECT MANAGEMENT SYSTEMS

GREEN ZONE PTY LTD.

25, 479 Warrigal Road, Moorabbin Victoria, Australia 3189

Phone: **+61 (0)3 9555 7876**

Email: **info@greenzonebarrier.com**

Website: **www.greenzonebarrier.com**